



Features

- Energy-saving, blocking hazardous fluid.

Specification

- IP65 waterproof coil.
- Continuous cycle, 100% ED.
- Open: 100~200ms, Close: 200~400ms

Power consumption

Coil power	2L
DC 6V/12 (W)	6.9
DC 24V (W)	6.0

Dimensions

Model	MUSL
Code	15
Dimension (mm)	
C	65
D	24
H	77
L	55
W	38
N.W (kg)	0.30

Circuit diagram

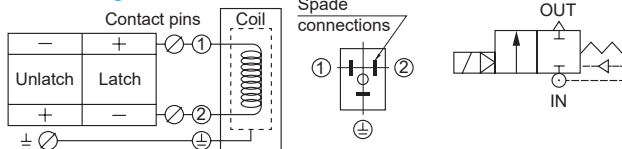

Order example

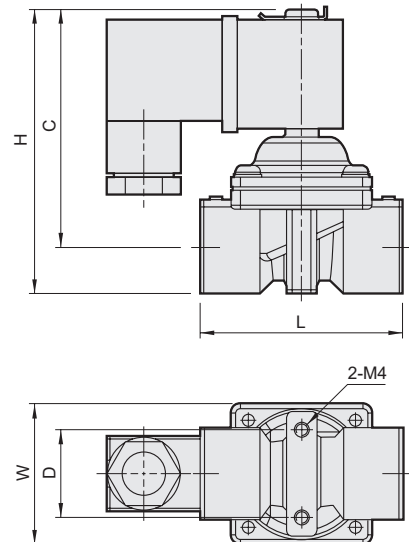
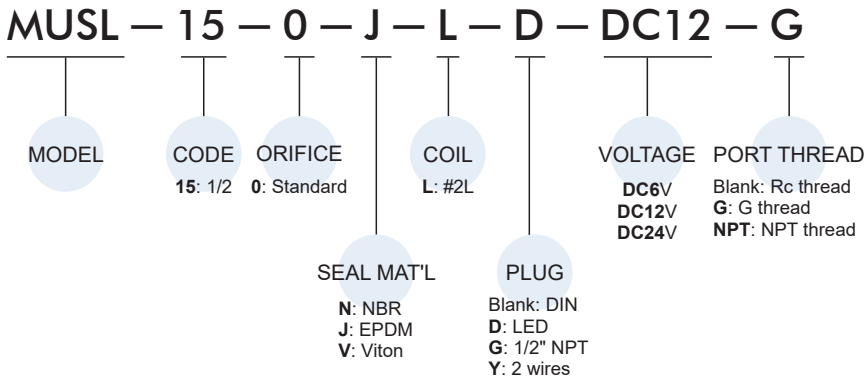

Specification

Model MUSL: SCS14 S.S. body, #304 cover, for water, air, gas, light oil, vacuum etc. 2/2 way N.C.									
Code (Port)	Seal mat'l	Coil	Orifice mm	Temp. °C		Working press. (0~ bar)		CV	Torr
				Coil L		Coil L			
				N	J, V	gas	liquid		
15(1/2)	N J V	2L	15	-5 ~ 60	-10 ~ 60	5	3	2	10 ⁻¹