

METFB-25 series

SLIDER ELECTRIC CYLINDER (WITHOUT MOTOR)

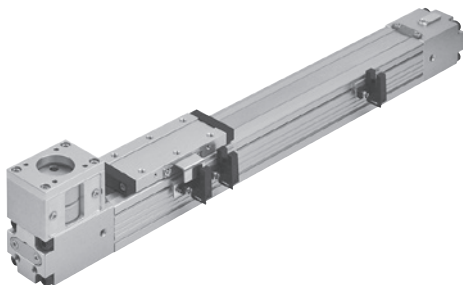

Motor type	Servo / Step	Transmission	Timing belt
Environment	Standard	Guide type	Linear guide

Specification

Model	METFB-25	
Positioning repeatability (mm)	±0.05	
Lead (mm/rev)	50	
Belt pitch (mm)	2	
Stroke (mm)	100~1000	
No-load torque (N.m)	0.1	
Slot-type photomicro sensor	RLT (Please refer to page 5-16)	

Motor type	AC servo		Step
Power output / size	50W	100W	□42
Max. speed *1 (mm/s)	1500		500
Work load *2	Horizontal (kg)	1.7	3.5
	Vertical (kg)	—	—

*1. Acceleration and deceleration values are set to 0.5 second.
*2. Not available for vertical installation.

Order example of electric cylinder

METFB-25 N - 1000 BW - S42

Model	Size	Stroke	Motor position	Flange (For motor installation)																															
METFB-25	N	1000	BW	S42																															
<table border="1"> <thead> <tr> <th colspan="2">Guide installation</th> </tr> </thead> <tbody> <tr> <td>N</td> <td>Without guide</td> </tr> <tr> <td>GR</td> <td>Guide right side</td> </tr> <tr> <td>GL</td> <td>Guide left side</td> </tr> </tbody> </table>		Guide installation		N	Without guide	GR	Guide right side	GL	Guide left side	100~1000 mm	<table border="1"> <tbody> <tr> <td>BW</td> <td>Top side</td> </tr> <tr> <td>BM</td> <td>Down side</td> </tr> </tbody> </table>	BW	Top side	BM	Down side	<table border="1"> <thead> <tr> <th colspan="2">Applicable motor brand (*1)</th> <th colspan="2">Dimensions</th> </tr> </thead> <tbody> <tr> <td rowspan="3">M</td> <td>Mitsubishi</td> <td rowspan="3">10</td> <td rowspan="3">50/100W Servo</td> </tr> <tr> <td>Yaskawa</td> </tr> <tr> <td>Delta</td> </tr> <tr> <td>P</td> <td>Panasonic</td> <td></td> <td></td> </tr> <tr> <td>S</td> <td rowspan="2">Mindman</td> <td rowspan="2">42</td> <td rowspan="2">□42 Step (*2)</td> </tr> <tr> <td>B</td> </tr> </tbody> </table>	Applicable motor brand (*1)		Dimensions		M	Mitsubishi	10	50/100W Servo	Yaskawa	Delta	P	Panasonic			S	Mindman	42	□42 Step (*2)	B
Guide installation																																			
N	Without guide																																		
GR	Guide right side																																		
GL	Guide left side																																		
BW	Top side																																		
BM	Down side																																		
Applicable motor brand (*1)		Dimensions																																	
M	Mitsubishi	10	50/100W Servo																																
	Yaskawa																																		
	Delta																																		
P	Panasonic																																		
S	Mindman	42	□42 Step (*2)																																
B																																			

*1. Motor not included. Please refer to the "Motor Selection Table" on page 4-122 for details.
*2. Step motors are without brake.

Slot-type photomicro sensor set

RZ - EB2 - N

Sensor set	Sensor type
RZ	N
EB2	N
	P

* With RLT sensor, mounting seat, bolt and cable 2m.

Accessory kits

AK - EB2 - 25

Accessory kits	Size
AK	25
EB2	

* With light baffle and bolt.

Weight

Model	Basic weight METFB-25N	Stroke 100 mm METFB-25N	Basic weight (with guide) METFB-25G*	Stroke 100 mm (with guide) METFB-25G*
Size				
25	0.97	0.18	1.3	0.27

* The table lists the weight of motor mounting on top.

METFB-25 Guide installation & Sensor mounting



SLIDER ELECTRIC CYLINDER (WITHOUT MOTOR)

Mindman

Guide installation

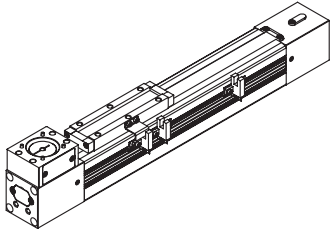

N Without guide

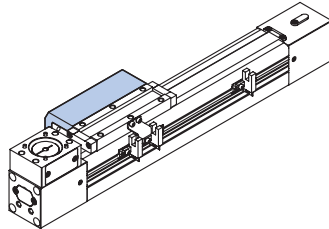

GR Guide right side

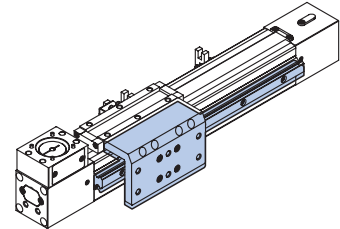

GL Guide left side

Motor position

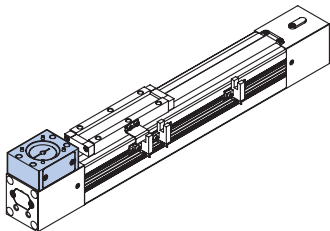

BW Top side

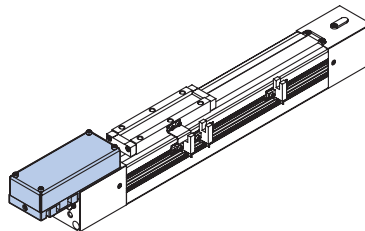

BM Down side

Slot-type photomicro sensor mounting

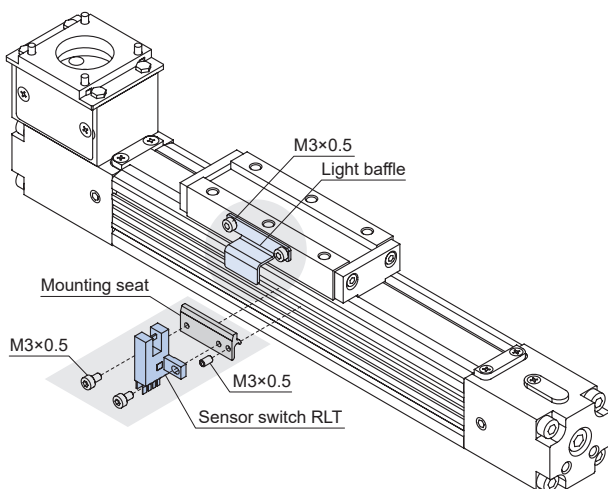

Sensor set

Sensor switch (×1)	Mounting seat (×1)	Bolt (×1)	Bolt (×2)

* With cable 2m.

Accessory kits

Light baffle (×1)	Bolt (×2)

METFB-25 Capacity

SLIDER ELECTRIC CYLINDER (WITHOUT MOTOR)

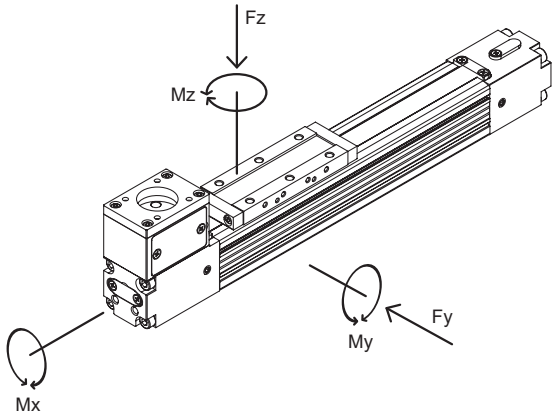

Forces & Moments

Model	Mx	My	Mz	Fy	Fz	
	Max. allowed moment (N.m)			Max. allowed load(N)		
METFB-25	Without guide	5	12	12	-	300
	With guide	38	42	42	2400	2700

Attention: In case of undefinable situations the above max. values have to be reduced by 10~20%.

Please refer to the following formula when combined loads are applied.

$$\frac{M_{xA}}{M_x} + \frac{M_{yA}}{M_y} + \frac{M_{zA}}{M_z} + \frac{F_{yA}}{F_y} + \frac{F_{zA}}{F_z} \leq 1$$

* The A letters show the calculated value.

Positioning of cylinder mountings

METFB-25 Without guide

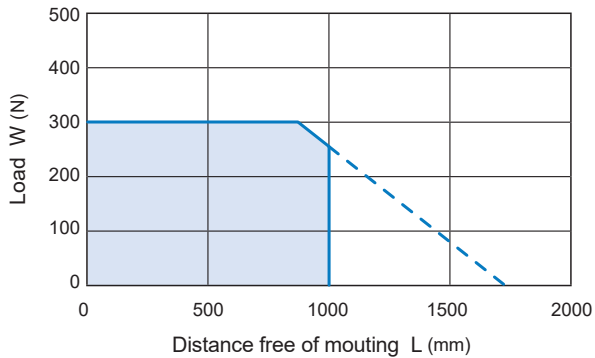

METFB-25 With guide

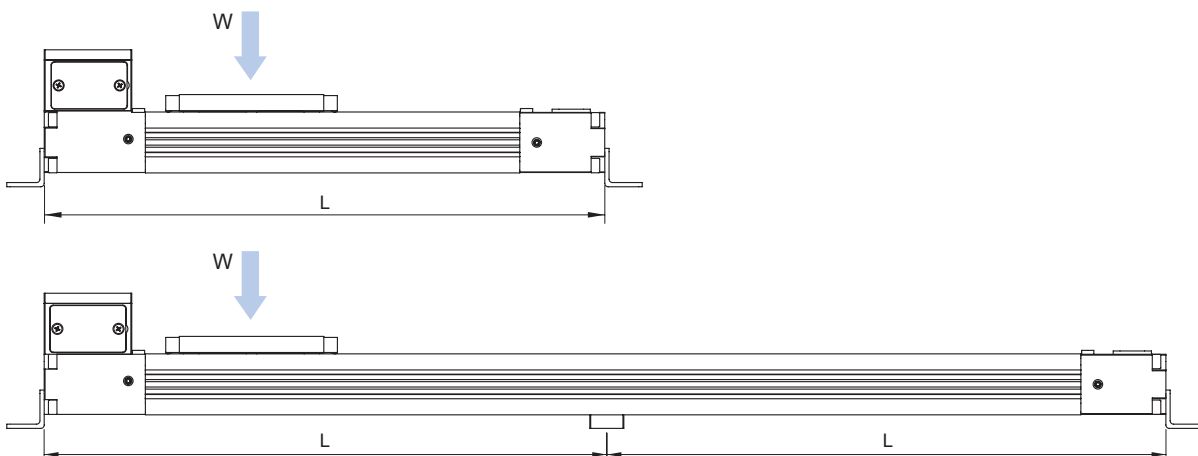
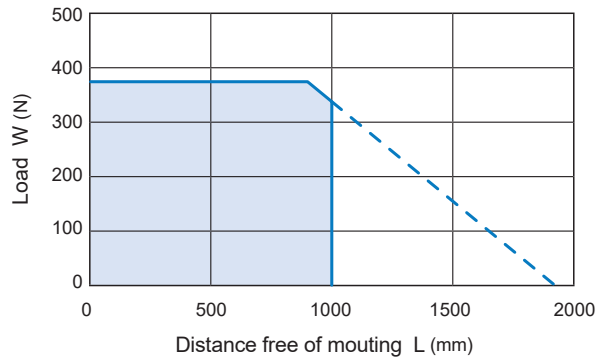

Diagram information

- Calculated deflections without support of 0.5~1 mm allow exceeding of the approved limits.
- Calculated deflections without support of > 1~1.5 mm require reduction of approved limits.

METFB-25 Dimensions

SLIDER ELECTRIC CYLINDER (WITHOUT MOTOR)



N BW Without guide • Motor top side

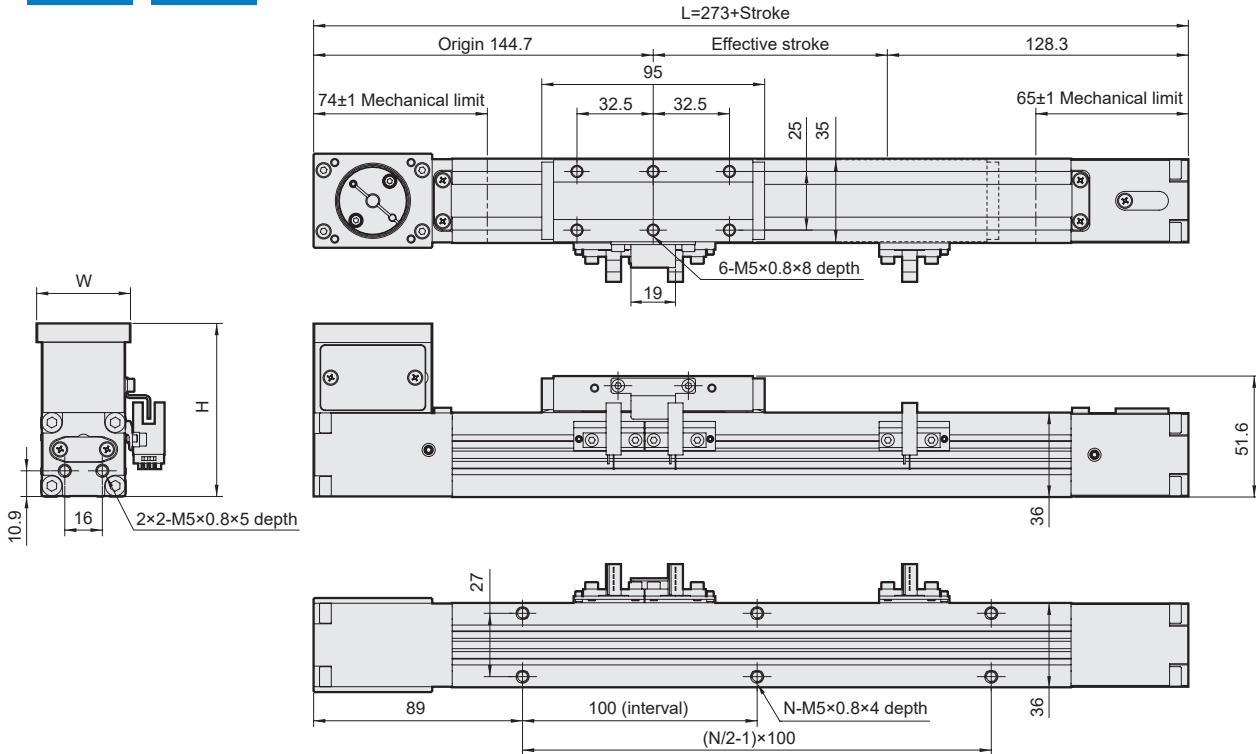

GL BW Guide left side • Motor top side

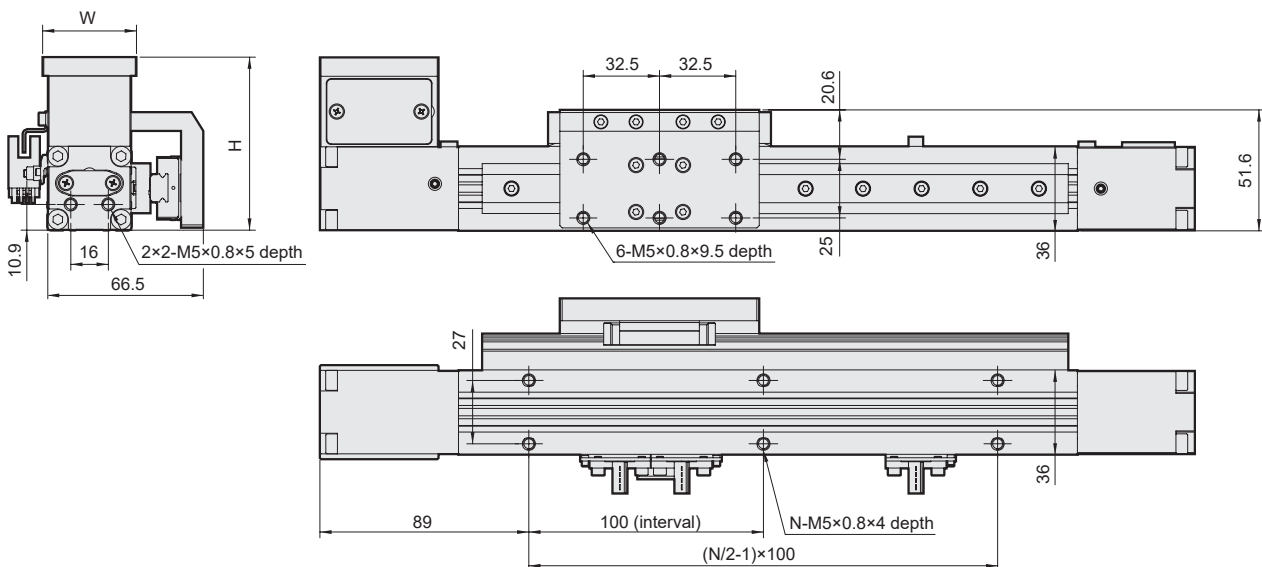

Unit: mm

Stroke Code	100	150	200	250	300	350	400	450	500	550	600	650	700	750	800	850	900	950	1000
L	373	423	473	523	573	623	673	723	773	823	873	923	973	1023	1073	1123	1173	1223	1273
N	6	6	8	8	10	10	12	12	14	14	16	16	18	18	20	20	22	22	24

Stroke Code	Servo	Step
W	40	42
H	73.8	71.8

METFB-25 Dimensions

SLIDER ELECTRIC CYLINDER (WITHOUT MOTOR)



mindman

N

BM

Without guide • Motor down side

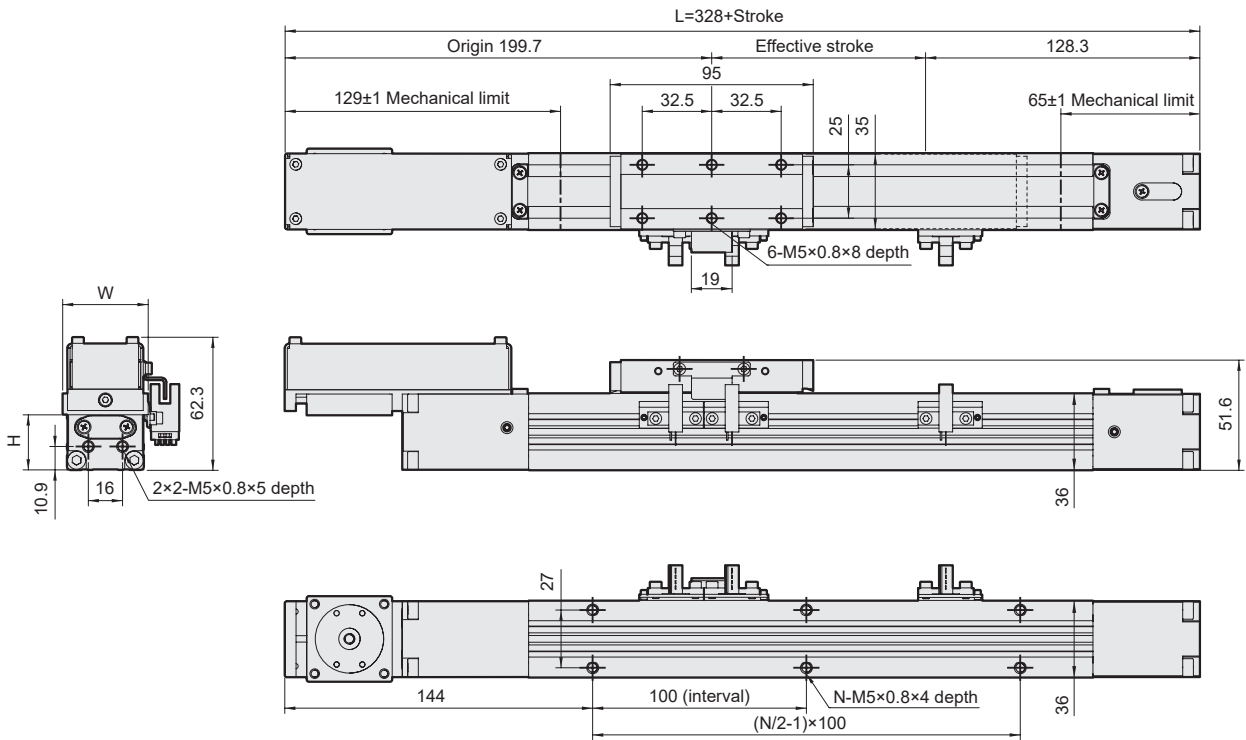

GL

BM

Guide left side • Motor down side

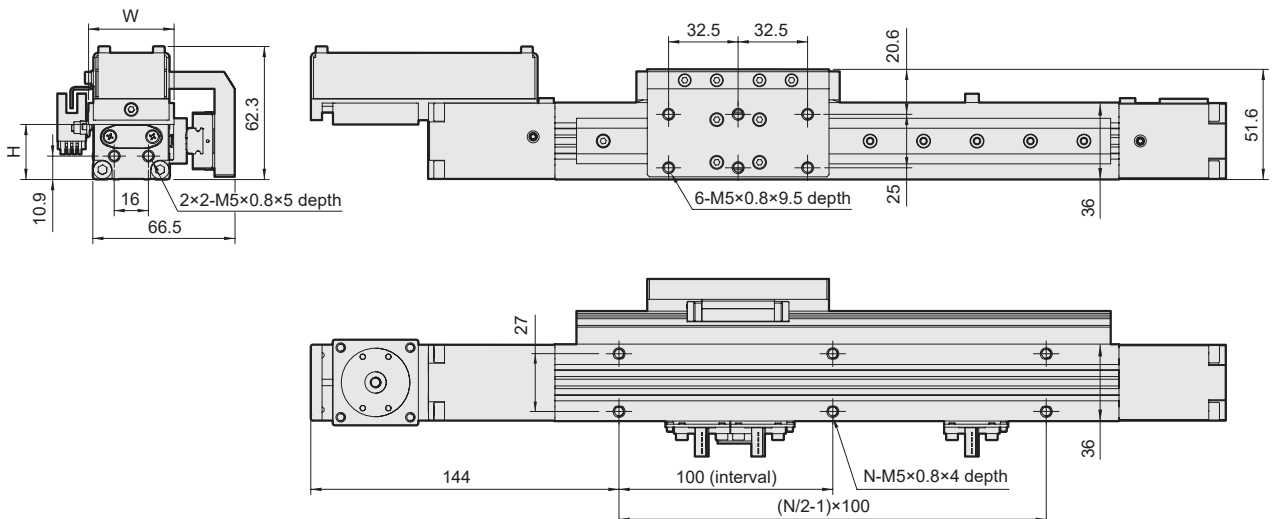

Unit: mm

Stroke Code	100	150	200	250	300	350	400	450	500	550	600	650	700	750	800	850	900	950	1000
L	428	478	528	578	628	678	728	778	828	878	928	978	1028	1078	1128	1178	1228	1278	1328
N	6	6	8	8	10	10	12	12	14	14	16	16	18	18	20	20	22	22	24

Stroke Code	Servo	Step
W	40	42
H	25.8	25.8

METFB-25 Mounting accessories

SLIDER ELECTRIC CYLINDER (WITHOUT MOTOR)



Mindman

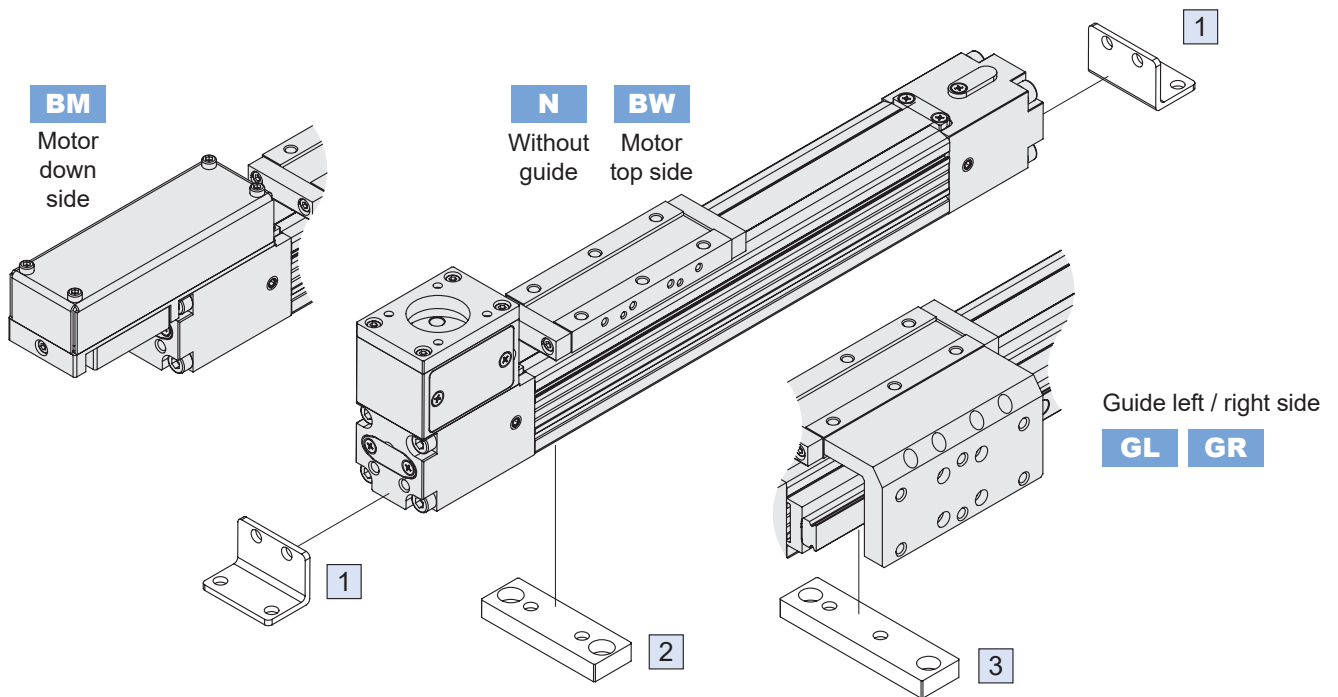

1 End cover bracket (2pcs/set)

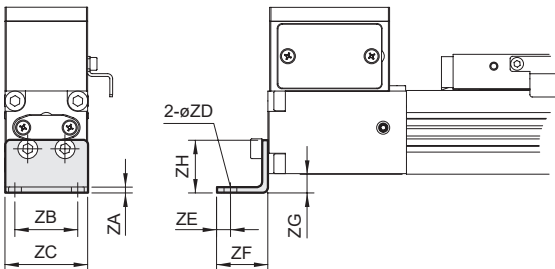

2 Mid section support *Applicable for (N) without guide.

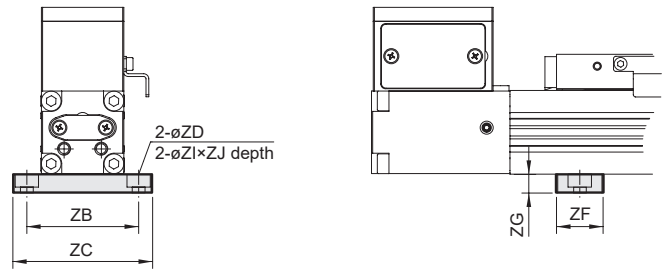

* Not applicable for (BM) motor down side.

3 Mid section support * Applicable for (GR / GL) with guide.

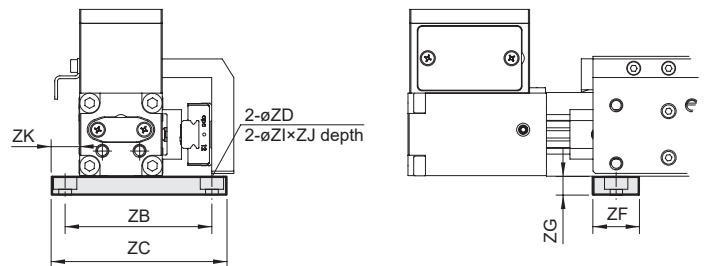

Unit: mm

Item	ZA	ZB	ZC	ZD	ZE	ZF	ZG	ZH	ZI	ZJ	ZK	Weight (g)	Order number
1	2.5	27	35.5	5.5	6	22	8	22.6	-	-	-	27	LB-EB2-25
2	-	48	60	5.5	-	20	8	-	10	5.5	-	21	MS-EB2-25
3	-	63	75	5.5	-	20	8	-	10	5.5	12	27	MS-EB2-25G