

Order example

MCHB – 16

MODEL

TUBE I.D.

- 12
- 16
- 20
- 25
- 32

Features

- Available with comprehensive range of Tube I.D. 12 ~ 32mm.
- Highly accurate air driven device for holding work-piece.
- Magnetic as standard.

Specification

Model	MCHB					
Acting Type	Double Acting					
Tube I.D. (mm)	12	16	20	25	32	
Port size	M3×0.5	M5×0.8				
Medium	Air					
Operating pressure range	0.15~0.7 MPa					
Ambient temperature	-5~+60°C (No freezing)					
Max. frequency	180 Cycles/min					
Lubrication	Cylinder	Not required				
	Lever	Grease (Actuation at)				
Max. arm length (L) (mm)	30	40	60	70	85	
Theoretical holding force (*1) (N)	Closed side	8	24	47	75	100
	Opened side	5	18	35	60	85
Lever open / close stroke	6	8	12	14	16	
Sensor switch (*2)	RDE, RDE-D					
Weight (g)	66	144	255	419	719	

*1. Gripping point length L=30mm, Pressure=0.5 MPa.

*2. RDE, RDE-D specification, please refer to page 5-6.

Length of gripping point

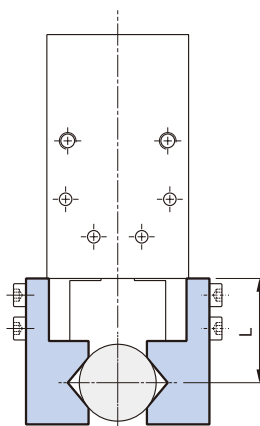

Installation of sensor switch

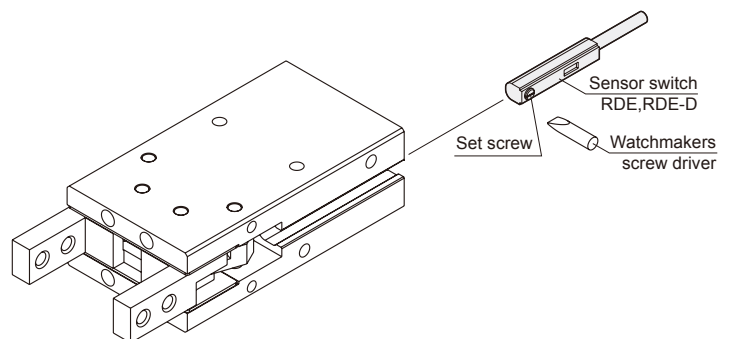

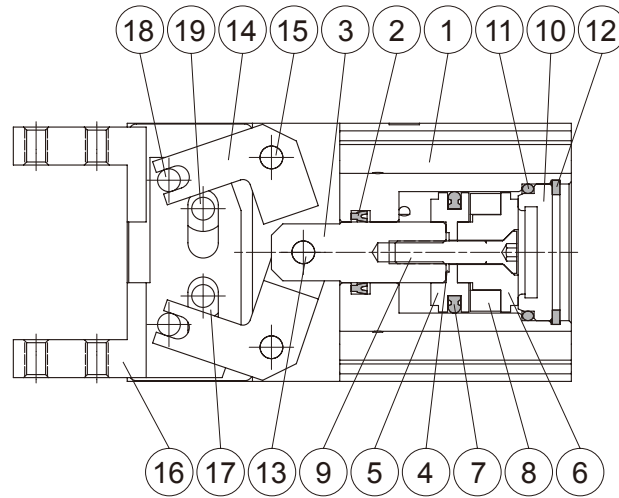

Material

No.	Part name	Material	Q'y	Repair kits (inclusion)
1	Body	Aluminum alloy	1	
2	Rod packing	NBR	1	●
3	Piston rod	Stainless steel	1	
4	Gasket	NBR	1	●
5	Piston-R	Aluminum alloy	1	
6	Piston-H	Aluminum alloy	1	
7	Piston packing	NBR	1	●
8	Magnet ring	Magnet material	1	
9	Screw	Stainless steel	1	
10	Head cover	Carbon steel	1	
11	Cover ring	NBR	1	●
12	Stop ring	Spring steel	1	
13	Spindle river	Bearing steel	1	
14	Grip per	Carbon steel	2	
15	Grip rivet	Carbon steel	2	
16	Grip per	Carbon steel	2	
17	Bush	Stainless steel	4	
18	Grip rivet	Bearing steel	2	
19	Grip rivet	Carbon steel	2	
20	Screw	SCM	4	
21	Screw	SCM	4	
22	Washer for grip	Stainless steel	2	

Order example of repair kits

Tube I.D.	Repair kits
ø12	PS-MCHB-12
ø16	PS-MCHB-16
ø20	PS-MCHB-20
ø25	PS-MCHB-25
ø32	PS-MCHB-32

PARALLEL GRIPPER (2-Finger)

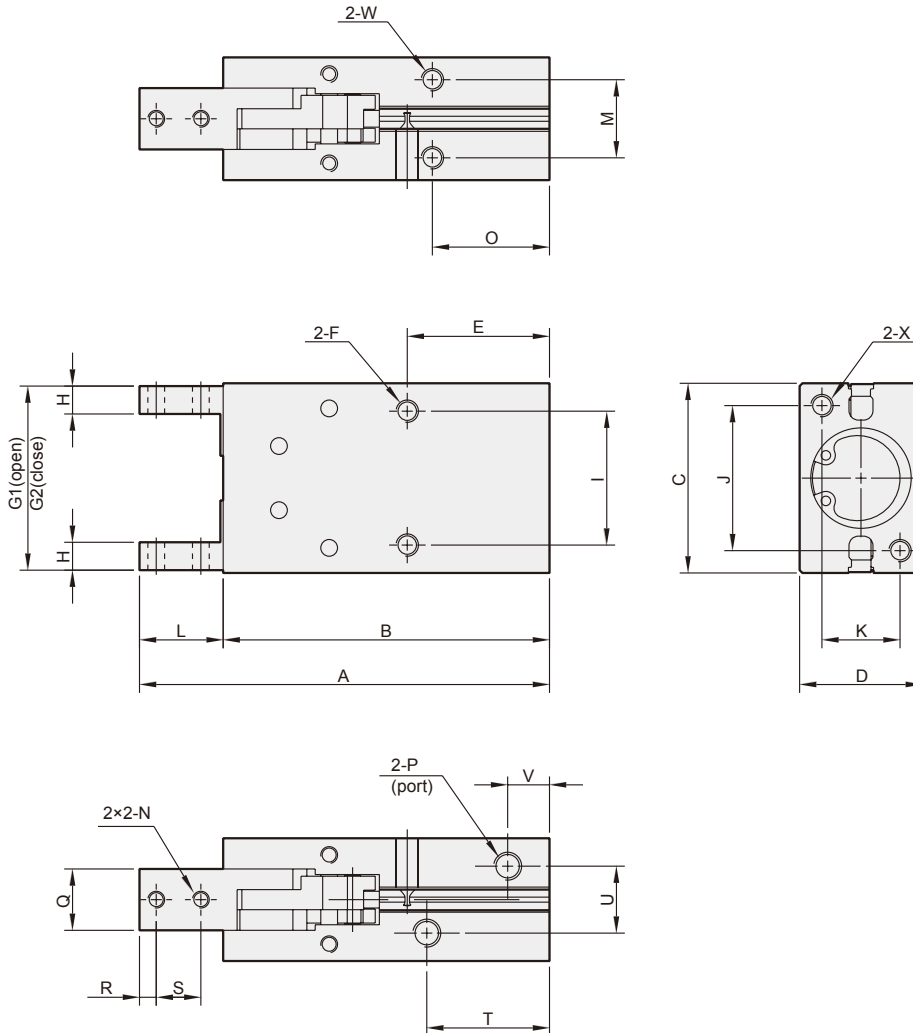

Code Tube I.D.	A	B	C	D	E	F	G1	G2	H	I	J	K	L	M	N	O	P	Q	R	S
12	63.5	50.5	28	16	20	M3×0.5×5 depth	27	21	4	18	17	10	13	10	M3×0.5	16	M3×0.5×5 depth	7	3	6
16	73.5	58.5	34	22	25.5	M4×0.7×11 depth	33	25	5	24	26	14	15	14	M3×0.5	21	M5×0.8×5 depth	11	3	8
20	88.5	69.5	45	26	25	M5×0.8×8 depth	44	32	6	30	35	16	19	16	M4×0.7	19	M5×0.8×5 depth	12	4	10
25	102.5	78.5	52	32	28	M6×1.0×10 depth	51	37	8	36	40	20	24	20	M5×0.8	22	M5×0.8×5 depth	14	5	12
32	120.5	90.5	60	40	34	M6×1.0×10 depth	59	43	10	44	46	24	30	26	M6×1.0	26	M5×0.8×5 depth	20	7	15

Code Tube I.D.	T	U	V	W	X
12	23	10.2	7.5	M3×0.5×5 depth	M3×0.5×5 depth
16	22	12	7.5	M4×0.7×7 depth	M4×0.7×7 depth
20	26	13	8	M5×0.8×8 depth	M5×0.8×8 depth
25	29	18	8.5	M6×1.0×10 depth	M6×1.0×10 depth
32	35	24	10.5	M6×1.0×10 depth	M6×1.0×10 depth