



Feature

- Patented lever-lock mechanism.
- Proximity sensors are available.
- Adjustable shock absorbers provide good capacity for different applications.
- Magnetic as standard.

Specification

Model	MSBE			
Tube I.D. (mm)	ø32	ø50	ø63	ø80
Stroke (mm)	20	30	30	40
Medium	Air			
Operating pressure range	0.2~1 MPa			
Proof pressure	1.5 MPa			
Ambient temperature	-5~+60°C (No freezing)			
Lubrication	Not required			
Cushion	External stopper	Adjustable shock absorber		
	Internal cylinder	NBR cushion pad		
Sensor switch	RDVE(V) (Please refer to page 8-19)			
Proximity sensor	RJY (Please refer to page 8-**)			
Weight	550 g	1930 g	3410 g	6340 g

Order example

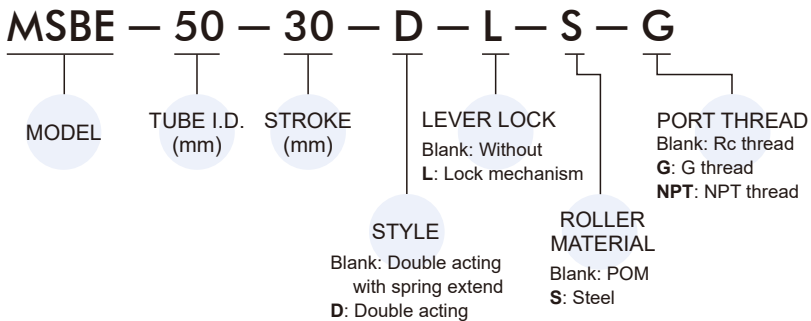

Piping diagram

Double acting with spring

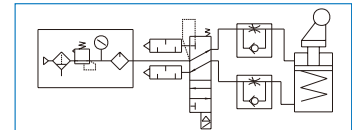

Double acting

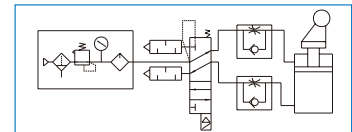

Intended use

Stopping transferred workpiece.

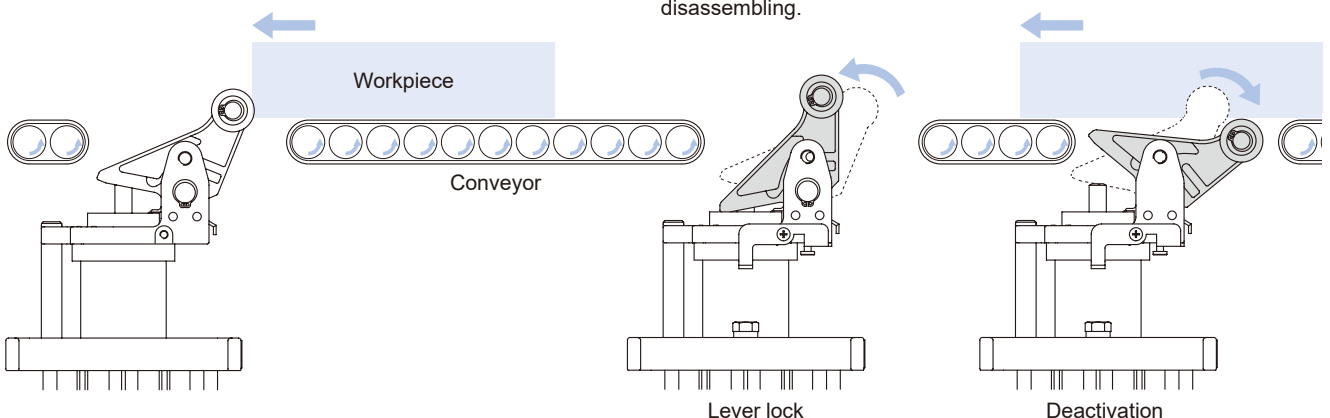

Lock & Deactivation mechanism

Lock mechanism prevents the light-weight workpiece from moving back by the force of shock absorber after damping.

Deactivation mechanism can deactivate the cylinder without any disassembling.

Pallet control stopper type

Thread (×2)

For inductive proximity sensor.

Guide rod

For protection against rotation.

Knurled cap

Step 1

Turn knurled cap until the desired cushioning is reached.

- Max mark: Cushion becomes harder.
- 0 mark: Cushion becomes softer.

Step 2

Tighten lock screw.
Tightening torque: 2 N.m

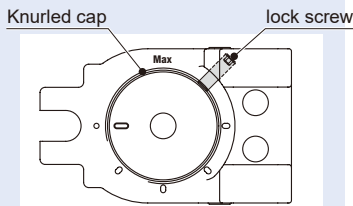

Through hole (×4)

For mounting.

Sensor switch groove (×6)

Stop roller (×2)

Roller toggle lever

(Optional)

Lock mechanism

For activating / deactivating lever position locking mechanism.

For $\varnothing 50 \sim \varnothing 80$, two pins for lever lock and deactivation mechanism are delivered for every L type MSBE.

The pin for lever lock function is installed before delivery. The other pin is attached in the package. Please see the assembling guide below for installing.

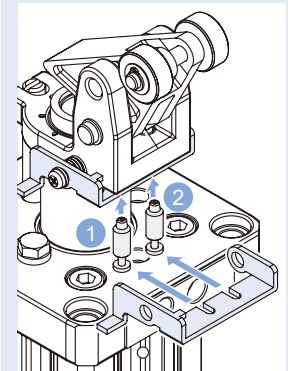

- 1 Lever-lock function
- 2 Free-pass function

1 Unlock bolt (Accessories)

The locking / deactivation mechanism of MSBE*-L* can be unlocked/reactivated by return the piston rod.

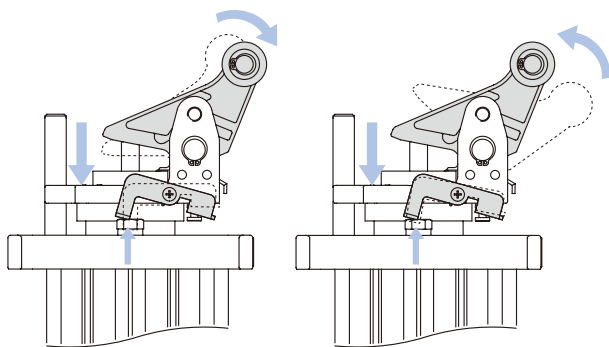

Unlocking locked lever

Unlocking free-pass

2 Port installation & Supply port (×2)

Select one set of port between the top one on the front cap and the one at the bottom.

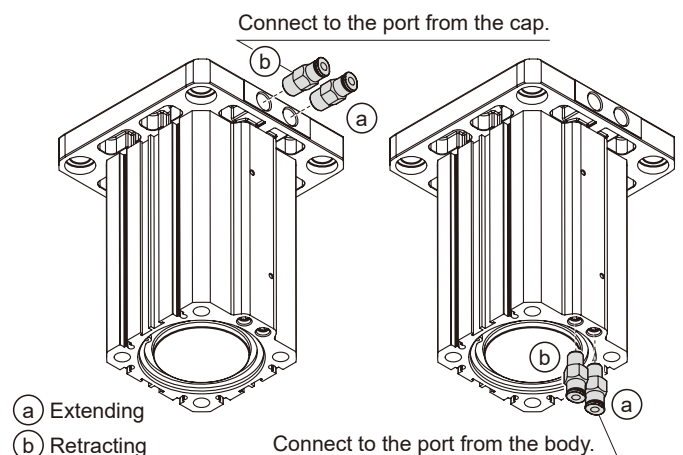

- Extending
- Retracting

Connect to the port from the body.

Load-speed chart for conveyor transmission

The chart is applied with the situation of friction coefficient $\mu = 0.1$.

ø32-20

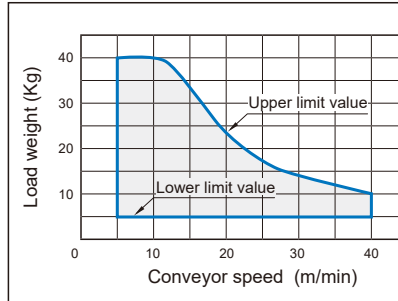

ø63-30

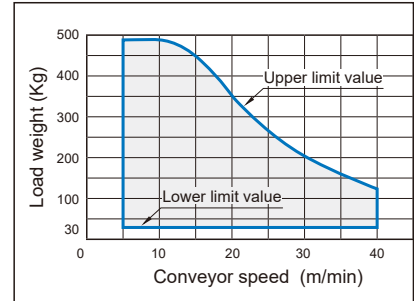

ø50-30

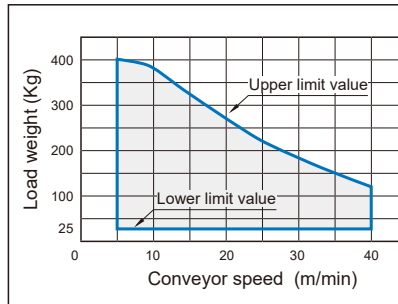

ø80-40

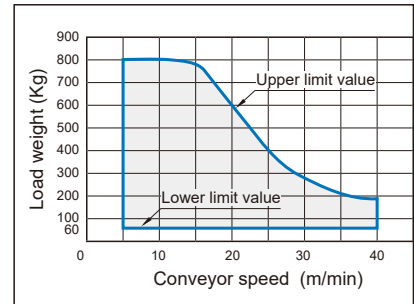

Lateral force-operation pressure chart

The lateral force is caused by the blocking object on the conveyor. The lateral force limit is proportional to operation pressure.

ø32-20

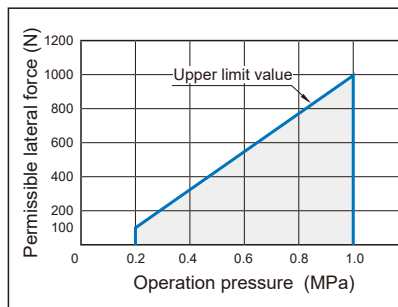

ø63-30

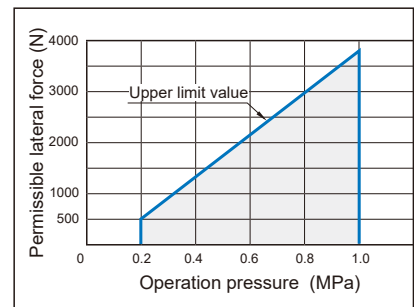

ø50-30

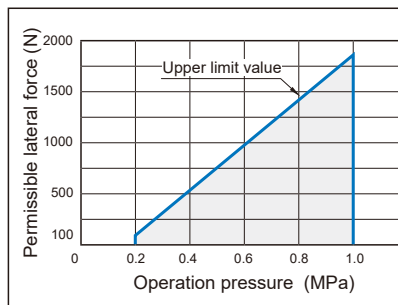

ø80-40

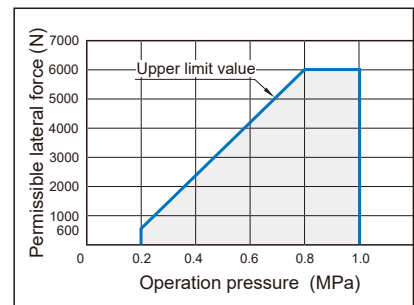

STOPPER CYLINDER

L: Lock mechanism

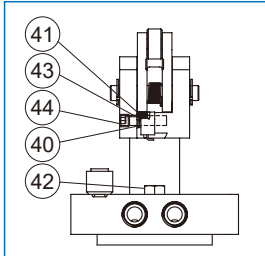

Free pass mechanism

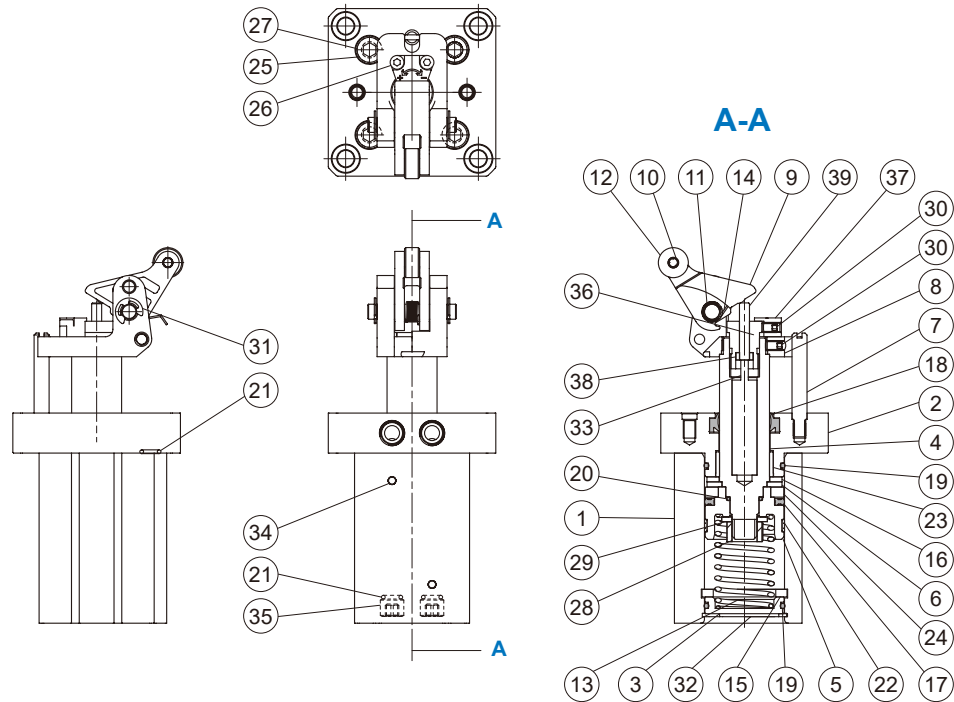
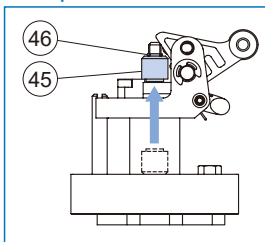

Material

No.	Part name	Material	Q'y
1	Body	Aluminum	1
2	Cover	Aluminum	1
3	Cover	Aluminum	1
4	Piston rod	Steel	1
5	Piston	Aluminum	1
6	Magnet holder	Aluminum	1
7	Guide rod	Steel	1
8	Lever holder	Steel	1
9	Lever	Steel	1
10	Roller pin	Steel	1
11	Lever pin	Steel	1
12	Roller	Resin	1
		Alloy steel *1	1
13	Piston spring	Steel	1
14	Lever spring	Steel	1
15	Cushion pad	NBR	1
16	Rod cushion pad	NBR	1
17	Piston seal	NBR	1
18	Seal	NBR	1
19	O-ring	NBR	2
20	O-ring	NBR	1
21	O-ring	NBR	4
22	Wear ring	Resin	1
23	Rod bush	NBR	1

No.	Part name	Material	Q'y
24	Magnet ring	Magnet	1
25	Hexagon bolt	Steel	4
26	Hexagon nut	Steel	2
27	Washer	Steel	4
28	Hexagon nut	Steel	1
29	Spring washer	Steel	1
30	Hexagon screw	Steel	2
31	Stop ring	Steel	2
32	Stop ring	Steel	1
33	Shock absorber	Steel	1
34	Ball	Steel	2
35	Plug	Alloy steel	2
36	Adjustable cap	Stainless steel	1
37	Damper lock	Stainless steel	1
38	Locating ring	Aluminum	1
39	Pin	Steel	1
40	Lever lock	Steel	1
41	Lock spring	Steel	1
42	Hexagon screw	Stainless steel	1
43	Pin	Steel	1
44	Hexagon screw	Steel	1
45	Locating pin	Aluminum	1
46	O-ring	NBR	1

*1. S type.

STOPPER CYLINDER

L: Lock mechanism

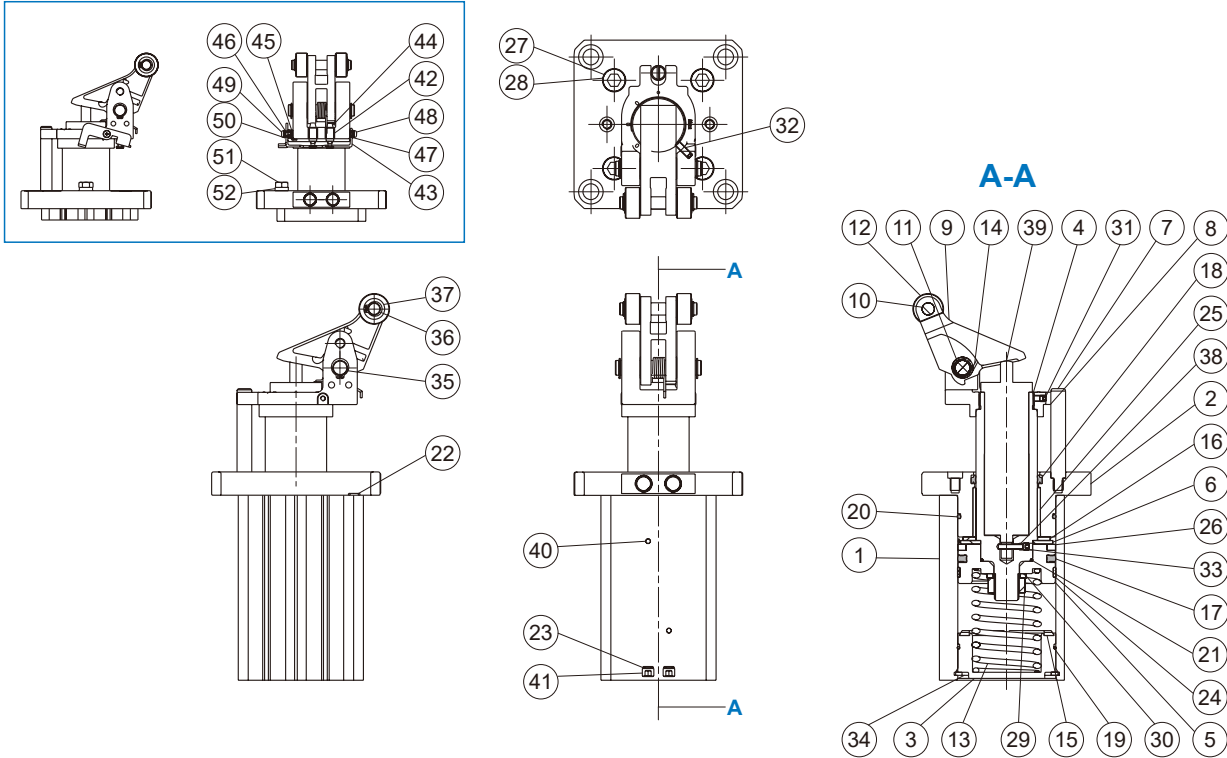

Material

No.	Part name	Material	Q'y / Tube I.D.		
			50	63	80
1	Body	Aluminum	1		
2	Cover	Aluminum	1		
3	Cover	Aluminum	1		
4	Piston rod	Steel	1		
5	Piston	Aluminum	1		
6	Magnet holder	Aluminum	1		
7	Guide rod	Steel	1		
8	Lever holder	Steel	1		
9	Lever	Steel	1		
10	Roller pin	Steel	1		
11	Lever pin	Steel	1		
12	Roller	Resin	2		
		Alloy steel *1	2		
13	Piston spring	Steel	1		
14	Lever spring	Steel	1		
15	Cushion pad	NBR	1		
16	Rod cushion pad	NBR	1		
17	Piston seal	NBR	1		
18	Seal	NBR	1		
19	O-ring	NBR	1		
20	O-ring	NBR	1		
21	O-ring	NBR	1		
22	O-ring	NBR	2		
23	O-ring	NBR	2		
24	Wear ring	Resin	1		
25	Washer	Resin	1		

*1. S type.

No.	Part name	Material	Q'y / Tube I.D.		
			50	63	80
26	Magnet ring	Magnet	1		
27	Hexagon bolt	Steel	4		
28	Washer	Steel	4		
29	Hexagon nut	Steel	1		
30	Spring washer	Steel	1		
31	Hexagon screw	Steel	1		
32	Hexagon screw	Steel	1		
33	Hexagon screw	Steel	-	1	
34	Stop ring	Steel	1		
35	Stop ring	Steel	2		
36	Stop ring	Steel	2		
37	Roller washer	Steel	2		
38	Spring pin	Steel	-	1	
39	Shock absorber	Steel	1		
40	Ball	Steel	2		
41	Plug	Steel	2		
42	Bush	Resin	2		
43	Lever lock	Steel	1		
44	Pin	Steel	2		
45	Spring	Steel	1		
46	Coller	Steel	1		
47	Coller #2	Steel	1		
48	Screw	Steel	1		
49	Screw	Steel	1		
50	Spring washer	Steel	1		
51	Hexagon screw	Steel	1		
52	Washer	Steel	1		

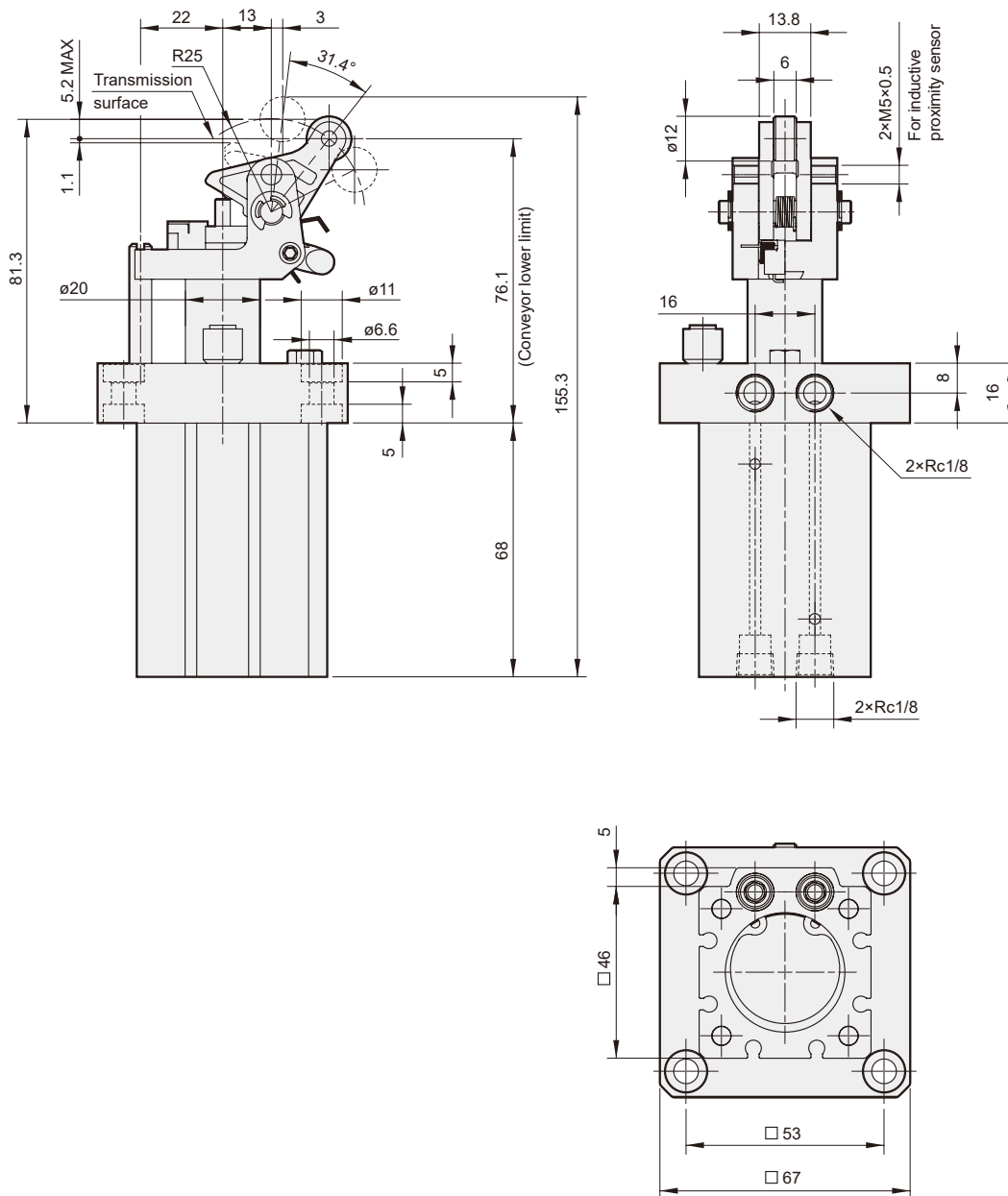

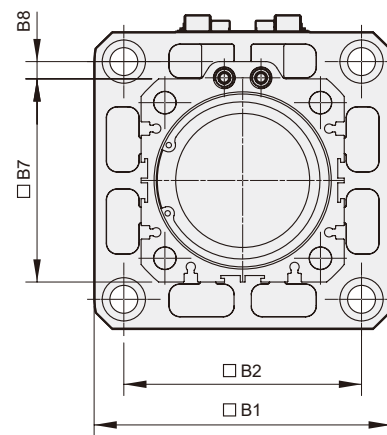
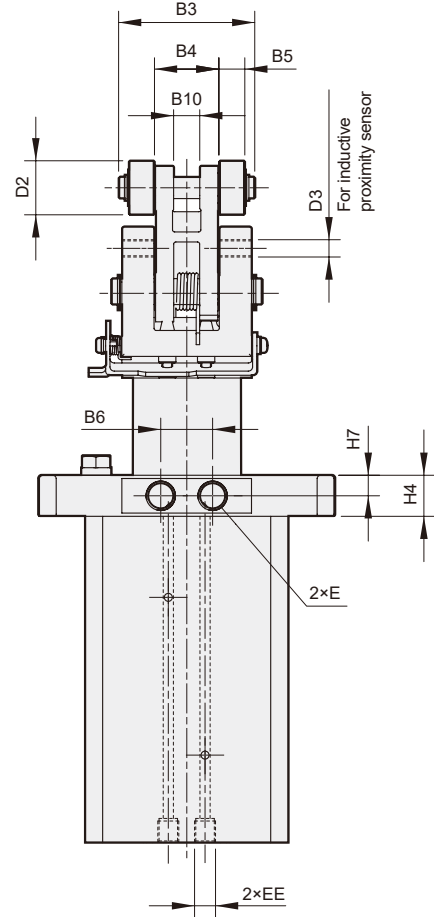
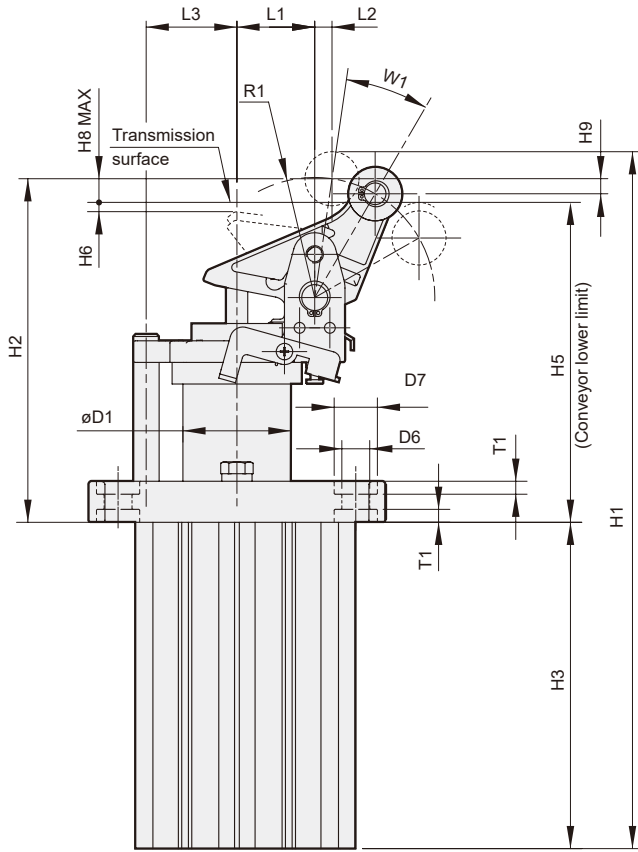

Code Tubr I.D.	B1	B2	B3	B4	B5	B6	B7	B8	B10
50	93	73	43	20	8	17	62	8	8.1
63	114	90	54	25	10	24	75	7	10.1
80	138	110	63	30	12	24	94	8	12.1

Code Tubr I.D.	D1	D2	D3	D6	D7	E	EE	H1	H2	H3	H4	H5	H6	H7	H8	H9	L1	L2	L3	R1	T1	W1
50	32	2- $\varnothing 20$	2-M8 \times 1	9	14	Rc1/8	Rc1/8	218.8	117.8	91	17.5	109.3	2.8	8.75	8.5	5.7	23	6.3	26	38.5	5	23.5°
63	40	2- $\varnothing 20$	2-M8 \times 1	11	18	Rc1/4	Rc1/8	251	134.0	107	25	126.3	6.3	12.5	7.8	4.8	29	6	34	44.4	6	20.3°
80	50	2- $\varnothing 25$	2-M8 \times 1	13	20	Rc1/4	Rc1/8	322.5	159.0	151	19	146.9	4.3	9.5	12.1	7	36	8	42	55.6	6	21.9°