



Order example

MCHQ – 64 M – OS

MODEL

BODY DIAMETER

64
80
100
125
160

M: Magnet

* Magnetic as standard.

Mechanical gripping force safety device for O.D. gripping even with a drop pressure.

Features

- Compact design enables gripper to be used for a wide range of industrial applications.
- Unit takes high bending moments whilst still giving high gripping force.
- Magnetic as standard.

Specification

Model	MCHQ				
Acting type	Double acting				
Body diameter (mm)	64	80	100	125	160
Stroke (mm)	12	16	20	26	32
Medium	Air 0.3~0.7 MPa				
Ambient temperature	-5~+60°C (No freezing)				
Lubrication (*1)	Not required				
Sensor switch (*2)	RH: Reed switch, RHN: NPN, RHP: PNP				
Weight (kg)	0.28	0.45	0.76	1.4	2.5

* 1. Maintenance: Re-Lubrication after appr. 1.5 million cycles recommended.

* 2. RH specification, please refer to page 5-12.

Gripping force in relation to the holding position "L" at 0.6 MPa

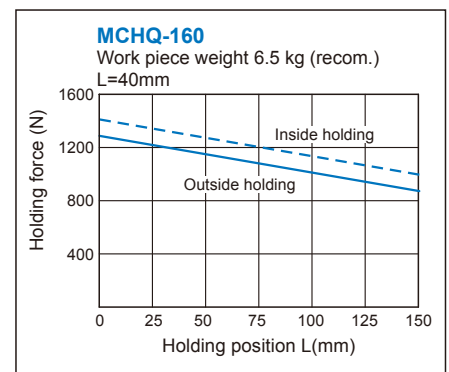
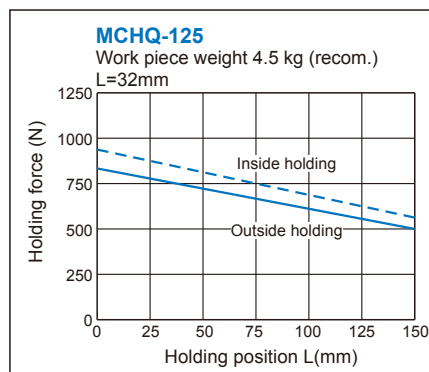
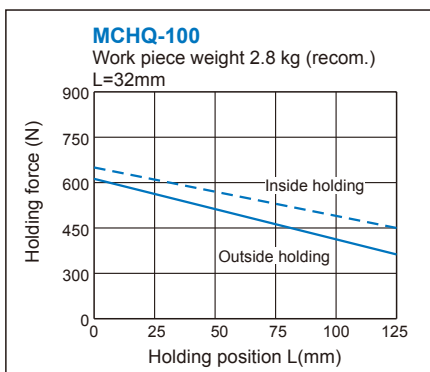
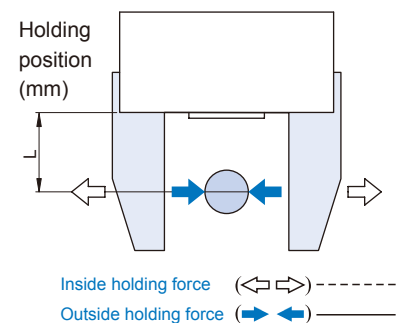
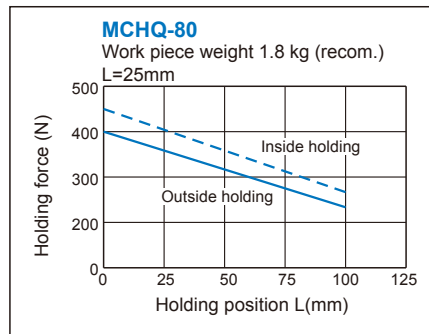
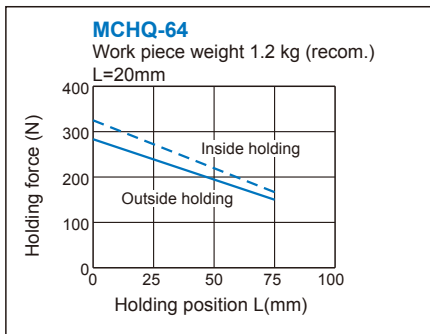

- With reference to the holding force, under the condition must be considered.
- Condition: friction coefficient, great acceleration impact is expected during work piece rotate.
- It recommend: select a type of arithmetic holding force that can produce 10 to 20 times for work piece weight.

PARALLEL GRIPPER (2-Finger)

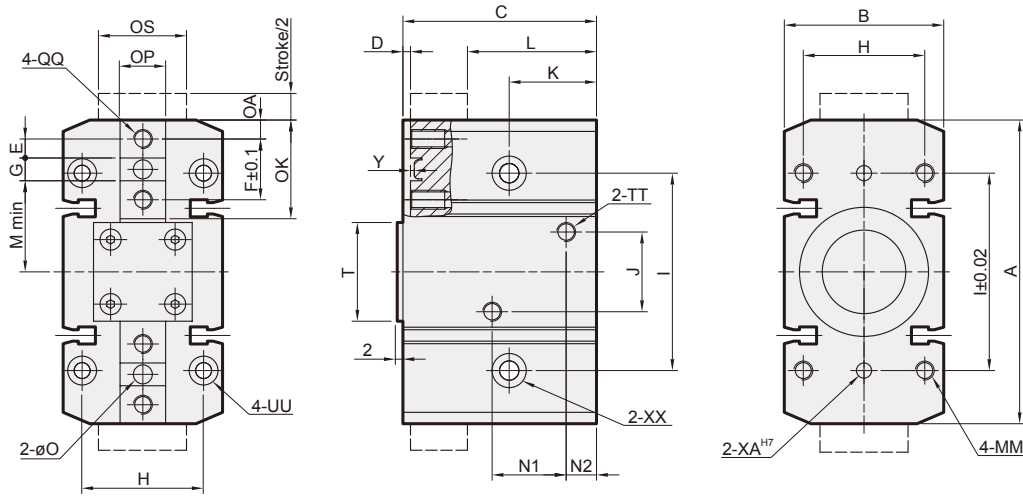

Code Model	A	B	C	D	E	F	G	H	I	J	K	L	M	MM	N1	N2	O	OA	OK	OP	OS	QQ	T	TT
MCHQ-64	64	36	42	2.5	4	13	5	27	42	16	22	27	19	M5×0.8	7	16.5	4	4	20	10	17	M4×0.7×8 dp	20	M5×0.8
MCHQ-80	80	42	51	2	5	16	6	32	52	21	23	34	24	M5×0.8	8	19.5	5	5	25	12	23	M5×0.8×10 dp	25	M5×0.8
MCHQ-100	100	50	59	3	6	20	8	38	66	46	20	40	30	M6×1.0	9.5	21.5	6	6	32	14	27	M6×1.0×10 dp	28	Rc1/8
MCHQ-125	125	60	68	3	8	24	8	45	82	55	36	44	38	M8×1.25	10.5	22	6	8.5	40	16	30	M6×1.0×12 dp	36	Rc1/8
MCHQ-160	160	72	82	3.5	11	32	10	56	100	58	34	55	50	M8×1.25	12	32	8	9	50	20	40	M8×1.25×16 dp	46	Rc1/8

Code Model	UU	XA	XX	Y
MCHQ-64	ø4.2 thru, ø7.5×26 dp	ø4	ø4.5 thru, ø8×8 dp	2.5
MCHQ-80	ø4.2 thru, ø7.5×34 dp	ø4	ø5.1 thru, ø9×24 dp	3
MCHQ-100	ø5.0 thru, ø9.1×45 dp	ø5	ø6.8 thru, ø11×11dp	3
MCHQ-125	ø6.8 thru, ø11×41 dp	ø6	ø9 thru, ø15×14 dp	3.5
MCHQ-160	ø6.8 thru, ø11×56 dp	ø6	ø9 thru, ø15×15 dp	4

Installation of sensor switch

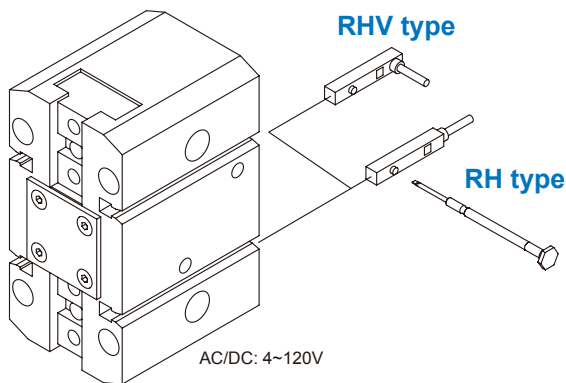

Gripping force safety device

Operating pressure min.5 bars, max. 6.5 bars

Gripping force = pneum. gripping force + spring force.

Gripping force in relation to the holding position "L" at 0.6 MPa

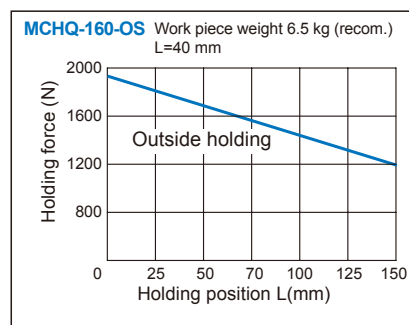
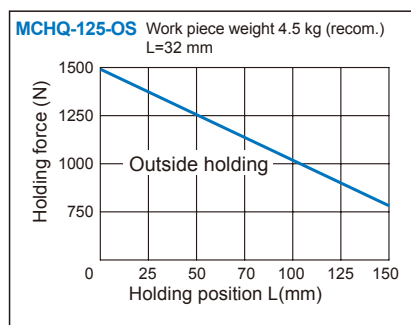
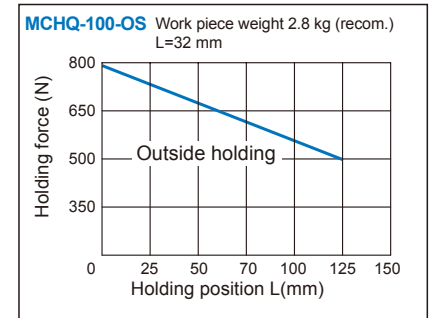
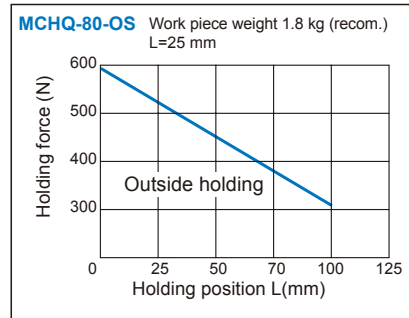
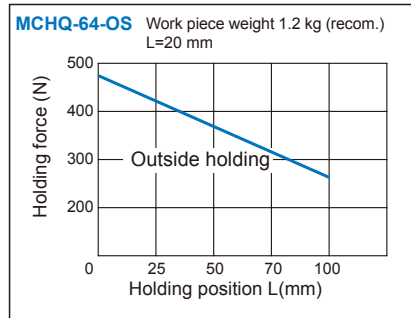

Gripping force safety device for O.D gripping, even with a drop in pressure.

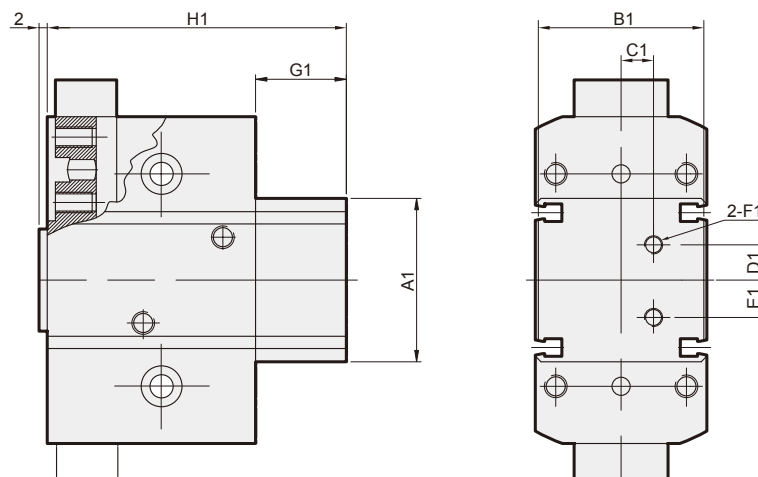

Code Model	A1	B1	C1	D1	E1	F1	G1	H1
MCHQ-64-OS	36	35.5	9	7	7	M5	25	67
MCHQ-80-OS	45	41.5	2	12	14	M5	27	78
MCHQ-100-OS	54	49.5	15.5	17	12	M5	26.5	85.5
MCHQ-125-OS	66	59.5	10	22	22	M5	34.4	102.4
MCHQ-160-OS	80	71.5	12.6	26.5	25	M5	39.2	121.2