

Features

- Cylinder remains same position when it reaches either end of stroke even if the input air source is gone.
- **Non lubrication**
 - Self-lubricating bush provides longer service life.
- **High quality long service life**
 - Stainless steel cylinder tubes for better corrosion resistance.
- **Magnetic as standard**

Specification

Model	MCMBL	
Tube I.D. (mm)	32	40
Port size	Rc1/8	Rc1/4
Medium	Air	
Max. operating pressure	1 MPa	
Min. operating pressure	0.15 MPa	
Proof pressure	1.5 MPa	
Lubricator	Not required	
Ambient temperature	-5~+60°C (No freezing)	
Available speed range	50~750 mm/sec	
Max. allowable kinetic energy (J)	Cushion pad	0.29
	Cushion air	0.32
Lock unit backlash	2 mm or less	
Sensor switch	RCM (Please refer to page 8-16)	
Sensor switch (band)	BM32	BM40

Table for standard stroke

Tube I.D.	Stroke (mm)
ø32, 40	25,50,75,100,125,150,200,250,300

Order example

MCMBL – 11 – 40 – 100 – AR – G

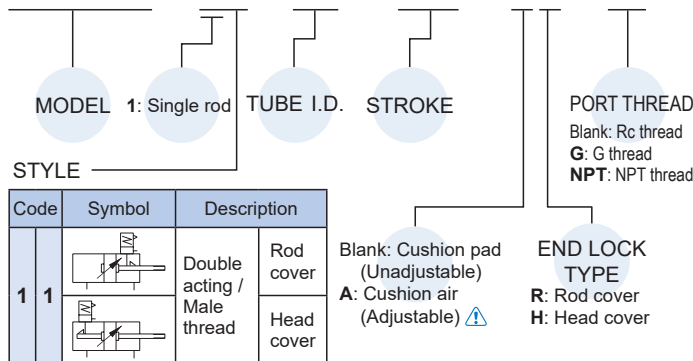

* For precautions, please refer to page 3-2.

* Order example for special specification, refer to page 0-7.





⚠️ Caution

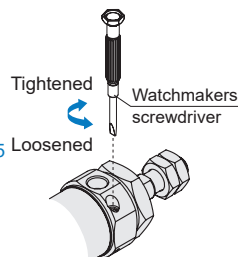

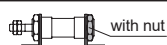
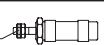

For (A) Cushion air (Adjustable)

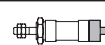
1. To adjust a cushion needle, please slowly turn the needle valve from the fully closed status to the required status which needs to be within 2.5 turns.
2. If the needle valve loosen excessively, the buffer doesn't take effect and the lifetime of cylinder would be shortened.





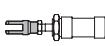
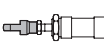

Accessories & Connector

Accessories					
Code	LB (LB×2, with cover nut ×1)	NUT		CA	CB
Mounting Tube I.D.	 with nut	Rod nut 	 Cover nut		
ø32	LB-M2-25x2	NUT-M10x1.25x6Hx17B	NUT-M26x1.5x8Hx32B	CA-M2-25	CB-M2-25
ø40	LB-M2-40x2	NUT-M14x1.5x8Hx22B	NUT-M32x2.0x10Hx41B	CA-M2-40	CB-M2-40

Accessories				Connector		
Code	FA	FB	TA	TB	Y	I
Mounting Tube I.D.						
ø32	FA-M2-25		TA-M2-25		Y-M2-25	I-M2-25
ø40	FA-M2-40		TA-M2-40		Y-Q1-40	I-M2-40

Pin

Applicable	Y&I connector	CA&CB accessories
Code	PIN-Y-P (with split pin / snap ring)	PIN-CB-P (with split pin / snap ring)
Fig Tube I.D.	 ø32  ø40	 ø32  ø40
ø32	PIN-M2-20-1-P	PIN-M2-20-1-P
ø40	PIN-M2-40-2-P	PIN-M2-40-1-P

END LOCK CYLINDER

Use recommended air pressure circuit

- 1 The circuit layout must be settled properly. The recommended circuit design is shown below.

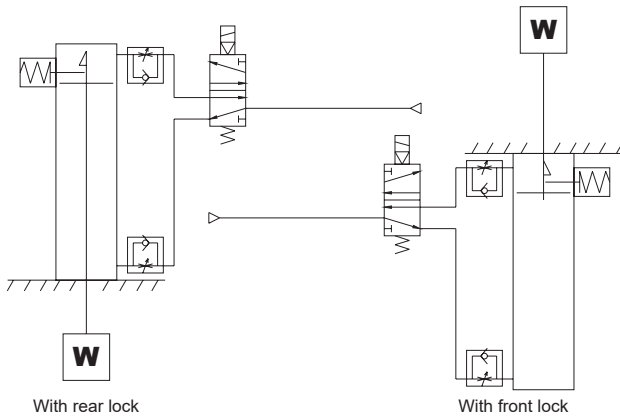

Maintains the cylinder's original position even if the air supply is interrupted.

Prevention of dropping at the rising end

With rear lock

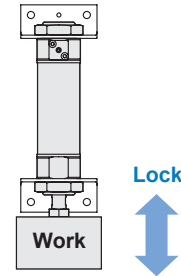

Locking of door With front lock

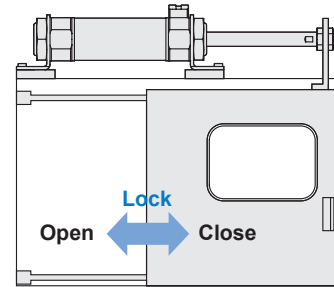

Precautions

- 1 Do not use 3-way solenoid valves. The cylinder cannot be locked when compressed air is trapped in the lock side port. And the lock may be released due to the air leakage of solenoid valve, even it was locked successfully.
- 2 Do not adjust or mount the cylinder when the lock is on.
- 3 The operation load do not exceed 50% of the cylinder maximum output.
- 4 Do not operate a workpiece with multiple end-lock cylinders simultaneously.
- 5 Use an one-way speed control valve with meter-out circuit layout design. The lock cannot be released when the circuit layout is meter-in design.
- 6 Operate the lock only when the cylinder is at the either end-position of stroke.
- 7 The air supply must be higher than 0.15 MPa to operate the lock.
- 8 The lock will be on when automatically when the pressure of the lock is lower than 0.1 MPa or less.
- 9 There are many conditions that will cause the exhaust speed to reduce. The examples are shown below.
 - a When the exhausting route length is too long.
 - b When the one-way speed control valve is too far from cylinder port.
 - c When the silencer of the solenoid valve is blocked or clogged.
- 10 When the cushion needle is fully closed, the piston rod may not be able to reach the end of its stroke. When the cushion needle is fully closed and the cylinder is locked, the lock may not be able to be released.

The replacement of rod sealing ring

- a Remove the retaining ring.
- b Take out the washer and clean it.
- c Take out the rod sealing ring.
- d Lubricate the new rod sealing ring and piston rod with grease.
- e Put in the new rod sealing ring.
- f Put in the washer.
- g Install the retaining ring.

Please contact our sales department for purchasing grease.

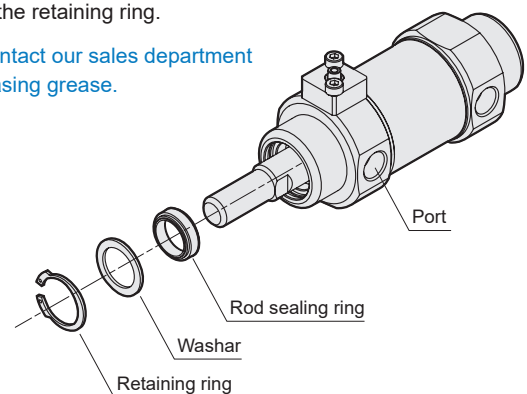

END LOCK CYLINDER

Manual Lock Releasing

- 1 Install a bolt into the locking rod and pull it up by hands. When your hands release, the locking rod will move back by spring force and continue locking.

The bolt size, inner spring pulling force and the stroke of locking rod are listed below.

MODEL	Thread size	Pulling force	Stroke (mm)
MCMBL-32	M2.5×0.45×25 ℓ	4.9 N	2
MCMBL-40	M3×0.5×30 ℓ	10.0 N	3

- 2 The bolt must be uninstalled after manual lock releasing, or the weight of bolt may cause some performance problems of the lock.

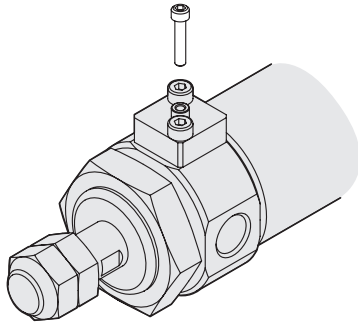

Installation of sensor switch

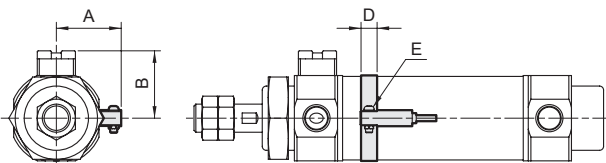
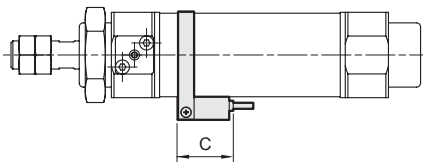
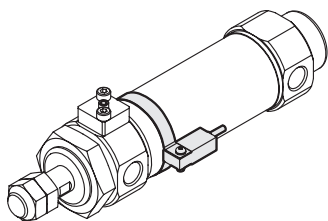

Code Tube I.D.	Sensor switch	Band	A	B	C	D	E
32	RCM	BM32	28.3	27.55	28	9	M3×16L
40	RCM	BM40	32.3	33.55	28	9	M3×16L

Working Principle

- Both front locking type and rear locking type have the same mechanism. The pictures below shows that how a rear locking type cylinder works.

- 1 When the air pressure is input from front cap, the piston will move backward. After the piston nears the end of the stroke, the slope of chamfered rod (the position of *mark) will touch the locking rod.

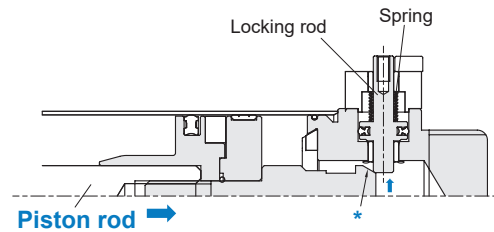

- 2 The locking rod will be guided with the slope and keeps moving upward.

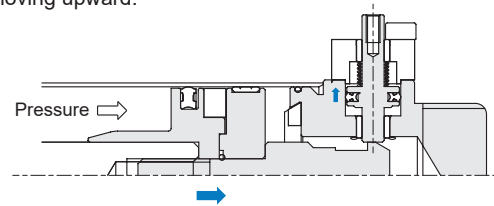

- 3 The locking rod will be pushed into the locking slot of the piston rod by the spring force. At this time, the cylinder is locked.

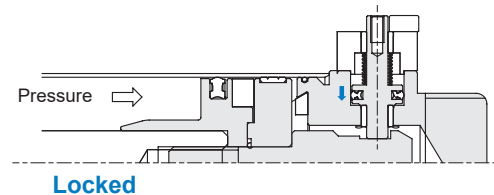

- 4 When the air pressure is input from rear cap, the piston will start moving forward. At the same time, the locking rod will be pushed up by the compressed air and make the piston rod unlocked.

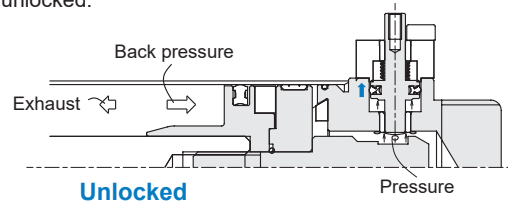

- 5 As the locking rod is no longer locking the piston rod, the cylinder can move forward.

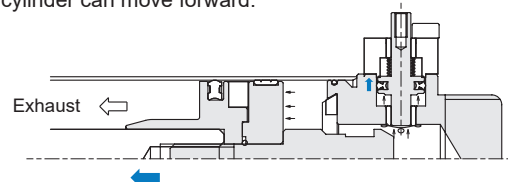

END LOCK CYLINDER

Cushion pad Unadjustable

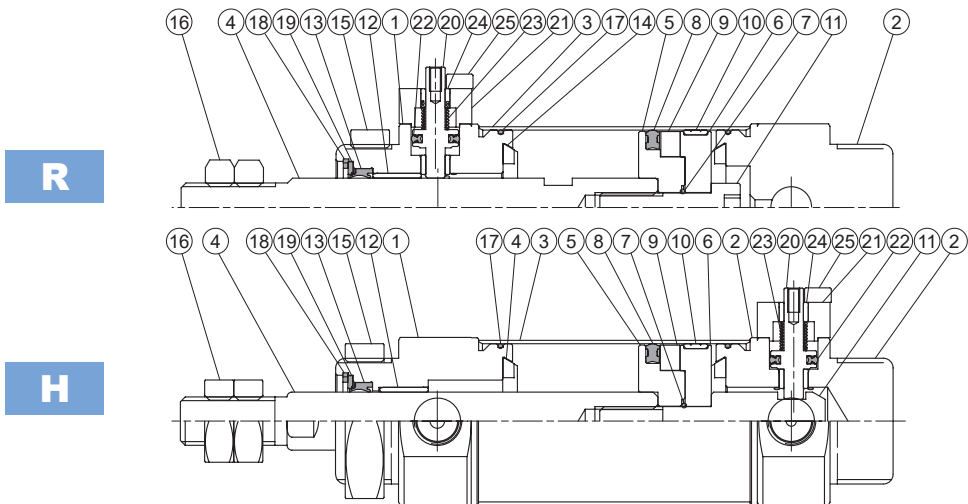

Cushion air Adjustable

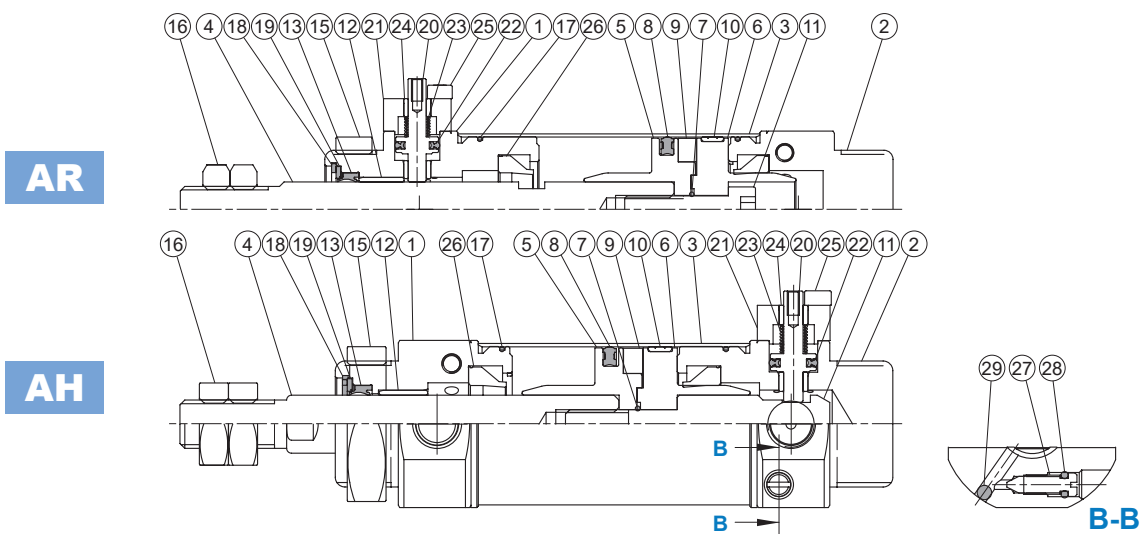

Material

No.	Cushion		Part name	Material	Q'y
	Pad	Air			
1	●	●	Rod cover	Aluminum alloy	1
2	●	●	Head cover	Aluminum alloy	1
3	●	●	Tube	Stainless steel	1
4	●	●	Piston rod	Carbon steel	1
5	●	●	Piston-R	Aluminum alloy	1
6	●	●	Piston-H	Aluminum alloy	1
7	●	●	O-ring	NBR	1
8	●	●	Piston packing	NBR	1
9	●	●	Magnet ring	Magnet	1
10	●	●	Wear ring	Resin	1
11	●	●	Piston bolt	Carbon steel	1
12	●	●	Rod bush	Bearing alloy	1
13	●	●	Rod sealing ring	HNBR	1
14	●	●	Cushion gasket	NBR	2
15	●	●	Cover nut	Carbon steel	1
16	●	●	Nut	Carbon steel	2

No.	Cushion		Part name	Material	Q'y
	Pad	Air			
17	●	●	O-ring	NBR	2
18	●	●	Retaining ring	Spring steel	1
19	●	●	Washer	Carbon steel	1
20	●	●	Lock piston	Carbon steel	1
21	●	●	Holder	Aluminum alloy	1
22	●	●	Piston packing	NBR	1
23	●	●	Spring	SWP	1
24	●	●	DU bush	-	2
25	●	●	Bolt	Carbon steel	2
26	●	●	Cushion ring	NBR	2
27	●	●	Cushion needle valve	Carbon steel	2
28	●	●	O-ring	NBR	2
29	●	●	Steel ball	Stainless steel	2

END LOCK CYLINDER

R

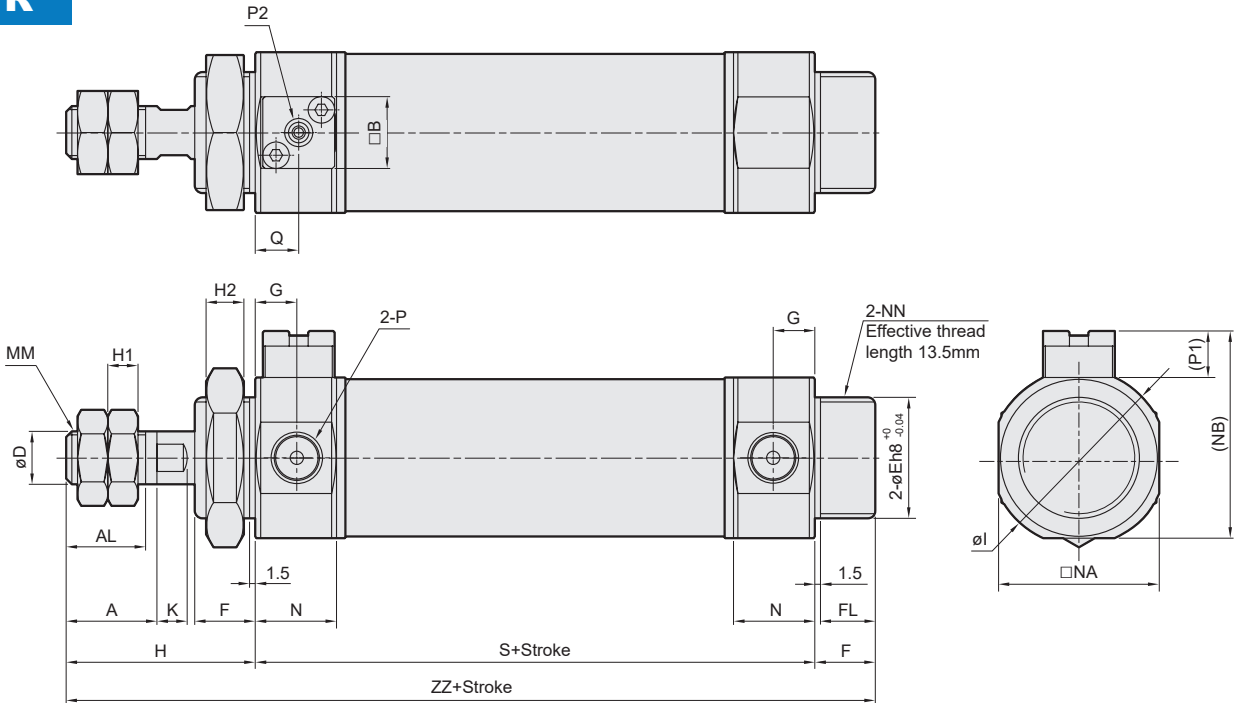

H

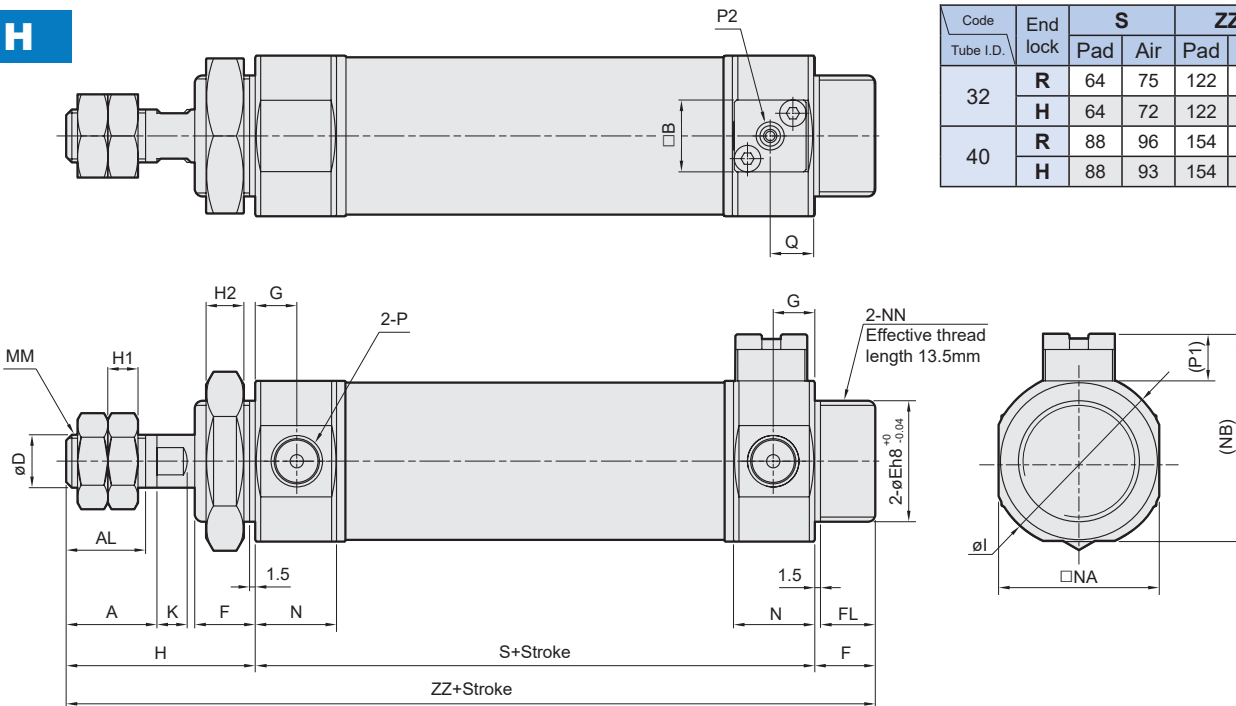

Code Tube I.D.	End lock	S		ZZ	
		Pad	Air	Pad	Air
32	R	64	75	122	133
	H	64	72	122	130
40	R	88	96	154	162
	H	88	93	154	159

Code Tube I.D.	A	B	AL	D	E	F	FL	G	H	H1	H2	I	K	MM	N	NA	NB	NN	P	P1	P2	Q
32	22	15	19.5	12	26	13	11.5	8	45	6	8	37.5	6.5	M10×1.25	15	34.5	44.8	M26×1.5	Rc1/8	10.3	M2.5×0.45	8
40	24	19	21	14	32	16	14.5	11	50	8	10	46.5	7	M14×1.5	21.5	42.5	54.8	M32×2.0	Rc1/4	12.3	M3×0.5	11.5