

## Pressure Switch with Super slim LED Display 8mm width LED Digital Pressure Sensor

- *Super slim and light weight pressure sensor with a LED display.*  
width: 8.2mm, height: 34.3mm, length: 62.2mm, weight: 17g
- *Indicator font size on the LED display is 4.5mm high for better visibility.*
- *All settings are done by 2 push buttons.*
- *Three mounting options : Bracket, DIN rail or via screws directly.*
- *Port selection: Single Port and Inline Port.*
  - *Port type: Female Thread (M5) and Push-In Fitting (ø 1.8, 3, 4mm).*

## 8mm width LED Digital Pressure Sensor

VACUUM GENERATOR  
EXTERNAL VACUUM CONTROLLER

VACUUM PAD

VACUUM ACCESSORIES

### Model Designation (Example)

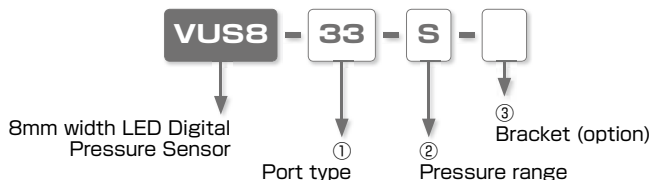

#### ① Port type

Port type	Push-In Fitting			Metric thread
Inline Port code	<b>180180</b>	<b>33</b>	<b>44</b>	<b>M5M5</b>
Single Port code	<b>180</b>	<b>3</b>	<b>4</b>	<b>M5</b>
Tube O.D. (mm)	∅1.8	∅3	∅4	M5×0.8

#### ② Pressure range

Code	<b>S</b>	<b>SR</b>
Pressure range	Negative pressure (-100 ~ 0kPa)	Compound pressure (-100kPa ~ 0.3MPa)

#### ③ Bracket (option)

Code	<b>No code</b>	<b>B</b>
Bracket (option)	without Bracket	with Bracket

### Model Designation of Bracket (Example)

**VUS8B**

※ 2 inner hexagonal bolts (M3x12) and 2 hexagonal nuts are included.

Small Vacuum Regulator  
Auto Back-Check Controller  
Vacuum Filter  
Free Holder  
Ball-Pressure Valve  
8mm LED Pressure Sensor

## Specifications

Model code		VUS8-□-S (Negative pressure)	VUS8-□-SR (Compound pressure)	
General spec.	Fluid medium	Air (non-corrosive air)		
	Pressure detection	Diffusion type semiconductor pressure switch		
	Operating temp. range	0 ~ 50°C (No freezing)		
	Storage temperature range	Atmospheric pressure / Humidity: 65% RH or less (No freezing)		
	Operating humidity range	35 ~ 85%RH (No dew condensation)		
	Vibration resistance	100m / s <sup>2</sup>		
	Impact resistance	150m / s <sup>2</sup>		
	Protective structure	Equivalent to IEC / IP40		
Pressure range	Operating pressure range	-100kPa ~ 0kPa	-100kPa ~ 0.3MPa	
	Proof pressure	500kPa	1.0MPa	
Power	Rated voltage	DC12-24V±10%, Ripple (P-P) 10% or less		
	Current consumption	30mA or less (all LED and no-load of 2 switch outputs: ON)		
Display	Display element	2-digits, 7-segment Red LED display (height: 4.5mm)		
	Display frequency	4 times / sec.		
	Monitoring system	Excessive rated pressure: Blinking display		
	Special functions	Panel Lock	ON / OFF by key	
		Display / Non-Display	ON / OFF by key	
	Pressure display magnification	×1(kPa)	Negative pressure ( ≤ 0kPa): (unit: kPa) Positive pressure (0kPa<): (unit: MPa)	
		×0.75		
	×0.01			
	×0.145			
	Pressure display range	-99 ~ 0(×1)	-99 ~ .30	
		-75 ~ 0(×0.75)		
-99 ~ -.00(×0.01)				
-14 ~ 0(×0.145)				
Sensor resolution	1(×1)	2kPa ( ≤ 0kPa) 0.01MPa (0kPa <)		
	1(×0.75)			
	0.01(×0.01)			
	1(×0.145)			
Indication accuracy	±1%F.S. ±1count			
Temperature characteristic	±3%F.S. (0 ~ 50°C, Reference temperature 25°C)			
Zero point adjustment	Adjustable by Zero Point Adjusting Mode			
Switch output	No. of pressure setting	2 switch outputs		
	Switch output	NPN open collector		
	Switch capacity	Max. DC30V 80mA		
	Residual voltage	Max. 1.28V (NPN, load current: 80mA)		
	Operating output	Separate Mode / Wind Comparator Mode		
	Pressure setting range	-99 ~ 0 counts (at kPa)	-99 ~ 30 counts	
	Operation indicator	Output ON: LED ON (SW1: Red, SW2: Green)		
	Temperature characteristic	±5%F.S. (0 ~ 50°C, Reference temperature 25°C)		
	Accuracy of response	±0.3%F.S.		
	Response time	Selectable (About 5, 25 and 250m · sec)		
	Hysteresis adjustment	Variable by hysteresis setting. 0-30 counts (VUS8- □ -SR, equivalent to 30kPa)		
Overload protection	N/A			

### Using Method

#### Wiring Connection Method

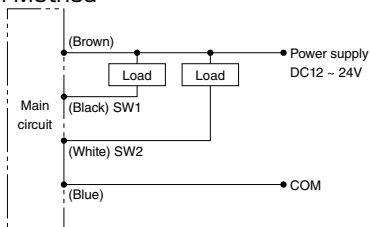

#### Names of the Panel Part

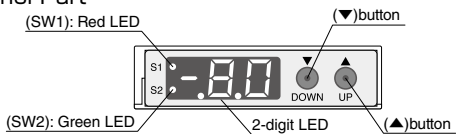

#### LED Display at Startup

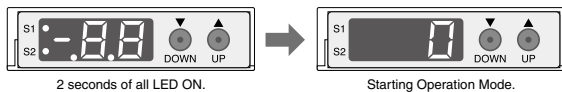

#### Operation Procedure of Panel

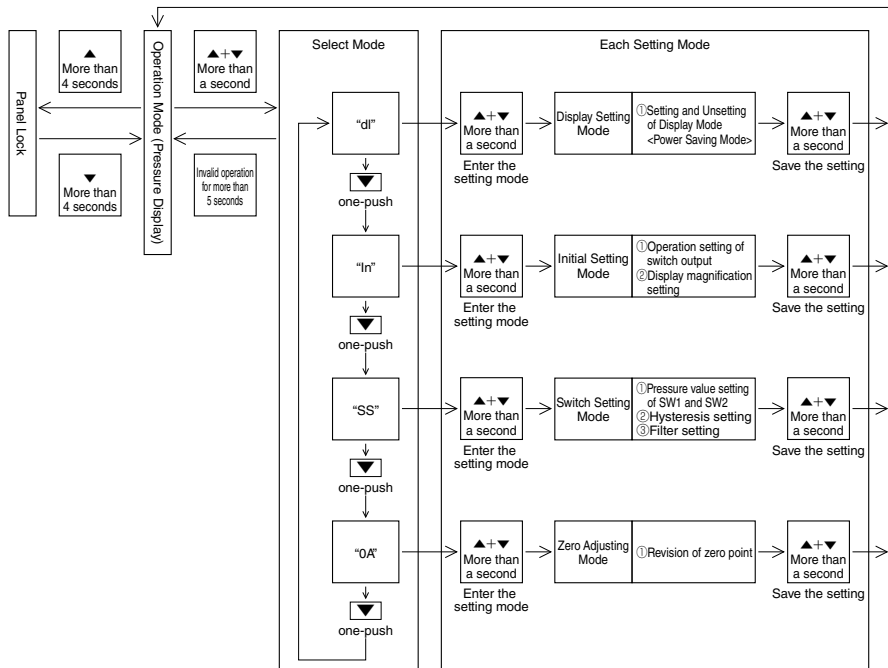

## ■ Operation Procedure of Panel

### ① Operation Procedure of Select Mode

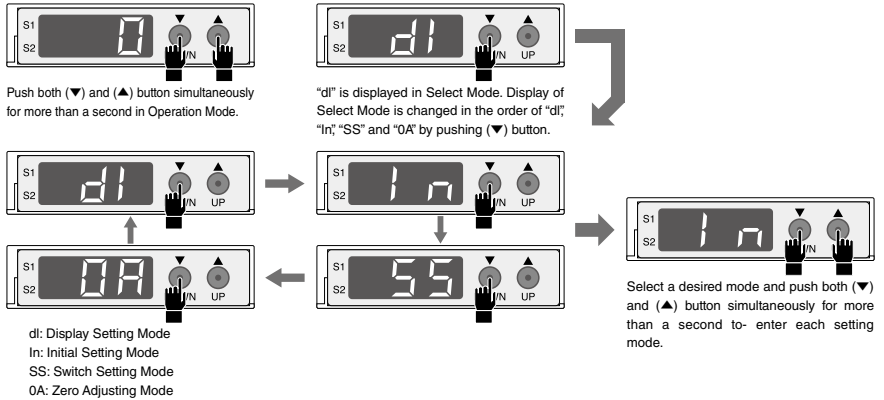

#### Caution

1. Display automatically returns to Operation Mode if no button is pressed for more than 5 seconds in Select Mode. Display does not return to Operation Mode even if no button is pressed for more than 5 seconds in Each Setting Mode.

### ② Selection of Display Mode <Display Setting Mode>

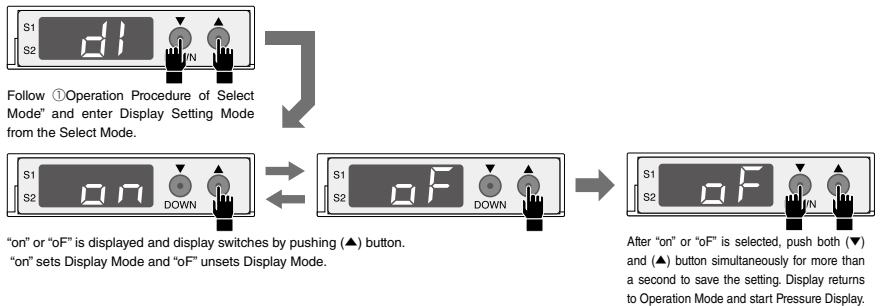

#### Caution

1. Display turns off, if no button is pressed for more than 10 seconds in Operation Mode after unsetting Display Mode. Display shows as follows. Red LED (S1) and Green LED (S2) turns on during the output of switch.

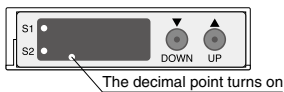

2. When temporarily Pressure Display needs to be displayed while Display Mode is unset, push (▼) or (▲) button. When there is no key operation for more than 10 seconds during Pressure Display, the display tuens off.
3. Factory setting is Display Mode "on".

## 8mm width LED Digital Pressure Sensor

VACUUM GENERATOR  
 EXTERNAL VACUUM CONTROLLER  
 VACUUM PAD  
 VACUUM ACCESSORIES

### ③ Setting Procedure of Display Magnification and Switch Output Operation <Initial Setting Mode>



Follow "① Operation Procedure of Select Mode" and enter Initial Setting Mode.



Display Magnification      Switch Output Operation  
 Current setting is displayed. Left digit shows Display Magnification No. and right digit shows Switch Output Operation No..



Display Magnification Setting or Switch Output Operation Setting can be selected by (▲) button. Blinking LED shows the setting item.



#### Display Magnification Setting



When Display Magnification needs to be set, turn on the left digit of LED and select Display Magnification No. with (▼) button. Every time (▼) button is pushed, the No. changes in the order of "1", "3", "4" and "5".  
 ※Refer to Display Magnification No. in the following table.

#### Switch Output Operation Setting



When Switch Output Operation needs to be set, turn on the right digit of LED and select Switch Output Operation by (▼) button. Every time (▼) button is pushed, the No. changes in the order of "1", "2", "3", "4", "5", "6", "7" and "8".  
 ※Refer to "Switch Output Operation No. / Operation Drawing" for Switch Output No..



After Display Magnification and Switch Output Operation are selected, push both (▼) and (▲) button simultaneously for more than a second to save the setting. Display returns to Operation Mode and starts Pressure Display.

※Before the above setting is completed, switch output operates in the previous setting before Select Mode. New setting is available after the above saving.

### Display Magnification No.

Display Magnification No.	Display Magnification	Pressure range	
		S : Negative pressure	SR : Compound pressure
1	x1 (kPa/MPa)	-99 ~ 0	-99 ~ .30
3	x0.75	-75 ~ 0	-
4	x0.01	-.99 ~ .00	-
5	x0.145	-14 ~ 0	-

#### Caution

- Follow "③ Setting Procedure of Display Magnification and Switch Output Operation <Initial Setting Mode>" to adjust settings.
- Factory setting is Display Magnification No. 1.
- Display Magnification "1" is only selectable for Pressure range "SR: Compound pressure". Negative pressure is shown by kPa and positive pressure is shown by MPa in "SR: Compound pressure".

Small Vacuum Regulator  
 Adion Block Controller  
 Vacuum Filter  
 Free Holder  
 Solenoid Valve  
 8mm LED Pressure Sensor

Switch Output Operation No. / Operation Drawing

Output Mode	SW1				SW2			
	Separate Mode		Wind Comparator Mode		Separate Mode		Wind Comparator Mode	
Operation	HI	LO	A	B	HI	LO	A	B
1	<input type="radio"/>				<input type="radio"/>			
2	<input type="radio"/>					<input type="radio"/>		
3		<input type="radio"/>			<input type="radio"/>			
4		<input type="radio"/>				<input type="radio"/>		
5			<input type="radio"/>				<input type="radio"/>	
6			<input type="radio"/>					<input type="radio"/>
7				<input type="radio"/>			<input type="radio"/>	
8				<input type="radio"/>				<input type="radio"/>
Pressure setting (Operating point)	Setting 1		Lower limit: Setting 1 Upper limit: Setting 2		Setting 2		Lower limit: Setting 1 Upper limit: Setting 2	

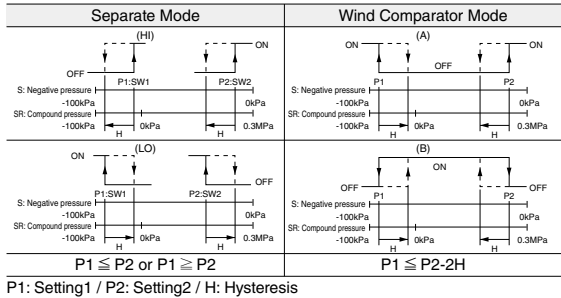

Caution

- Follow "③ Setting Procedure of Display Magnification and Switch Output Operation <Initial Setting Mode>" to adjust settings.
- Factory setting is Switch Output Operation No. 1 (Separate Mode: SW1 HI / SW2 HI).

## 8mm width LED Digital Pressure Sensor

## ④ Setting Procedure of Switch Pressure Value, Hysteresis and Filter &lt;Switch Setting Mode&gt;



Follow "① Operation Procedure of Select Mode" and enter Switch Setting Mode.

Pressure value setting of SW1

Pressure value setting of SW2



Filter setting



Hysteresis setting

S1 LED flashes and a current pressure value is displayed. "Pressure value setting of SW1", "Pressure value setting of SW2", "Hysteresis setting" and "Filter setting" are displayed in order by pushing both (▼) and (▲) buttons simultaneously.

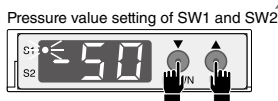

Pressure value setting of SW1 and SW2

Push (▼) or (▲) button to select the pressure value of SW1, when S1 LED flashes. Also, push (▼) or (▲) button to select the pressure value of SW2, when S2 LED flashes.

※When Wind Comparator Mode is selected in Switch Output Operation, the setting range of SW1 and SW2 is  $P1 \leq P2 \leq 2H$ .

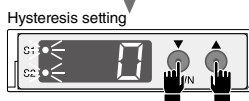

Hysteresis setting

Push (▼) or (▲) button to select the hysteresis value, when S1 and S2 LEDs flash.

※Setting range of Hysteresis is;  
S (Negative pressure): 0-30 counts  
SR (Compound pressure): 0-30kPa

※When Wind Comparator Mode is selected in Switch Output Operation, the setting range of Hysteresis is  $P1 \leq P2 \leq 2H$ .

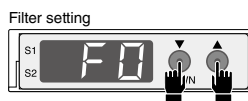

Filter setting

Push (▼) or (▲) button to select filter type.

※Filter selection is;  
F0: about 2msec  
F1: about 25msec  
F2: about 250msec



After the settings of Switch Pressure Value, Hysteresis and Filter are completed, push both (▼) and (▲) buttons simultaneously for more than a second in order to confirm the settings.

※Before the above setting is completed, switch output operates in the previous setting before Select Mode. New setting is available after the above operation.

## Caution

- Set Switch Pressure Value and Hysteresis after finishing "③ Setting Procedure of Switch Output Operation". Hysteresis setting value becomes "0", when the operating output is shifted from Separate Mode to Wind Comparator Mode. Also, Pressure value of SW1 changes to that of SW2. Make sure to set Switch Pressure Value and Hysteresis after setting Switch Output Operation.

## ⑤ Setting Procedure of Zero Point Adjustment &lt;Zero Adjusting Mode&gt;



Release the pressure in pressure port and follow "① Operation Procedure of Select Mode" to enter Zero Adjusting Mode.



If the display does not show "0", push both (▼) and (▲) button simultaneously to adjust zero-point.

※Zero point adjustment is available again and again.



Make sure the display shows "0" and push both (▼) and (▲) buttons for more than a second. Operation Mode comes out in the display and pressure detection starts.

## Caution

- "E2" is displayed, when more than  $\pm 10\%$  of the pressure is supplied to the pressure port. "E2" will be unset by (▲) button. (※ Return to Operation Mode)  
Make sure to adjust zero-point after releasing the pressure in pressure port.



## ⑥ Setting Procedure of Panel Lock

### Setting of Panel Lock

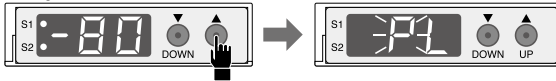

Press (▲) button for more than 4 seconds in Operation Mode. "PL" on the display flashes 3 times and Panel Lock will be set. The pressure display come back again after the setting.

### Unsetting of Panel Lock

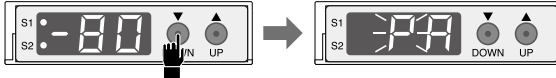

Press (▼) button for more than 4 seconds in Operation Mode. "PA" on the display flashes 3 times and Panel Lock will be unset. The pressure display comes back again after unsetting.

### Operation during Panel Lock

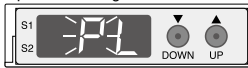

If any button operation is done during Panel Lock, "PL" on the display flashes 3 times and the pressure value is displayed again. The button operation is not available.

## Error Messages

Error messages	Error details	Countermeasures
	Require an investigation by PISCO.	Contact us.
	Pressure is supplied or a residual pressure still remains in a pneumatic system during Zero Point Adjustment.	Press (▲) button to unset "E2" and the display returns to Operation Mode. Release the pressure in pressure port and adjust zero-point again.
	The set data may have been lost.	Turn on the power to restart the sensor and check the initial and switch settings. When the sensor does not reset normally, contact us.
 Flash display	Pressure exceeds the detection range (110% FS).	Sensor is normally operated. Reduce the pressure within the spec. range.

## Replacement of Cartridge Fitting

To exchange the cartridge fitting, use a flathead screwdriver to pull out a fixing pin.

- ※ When replacing a cartridge fitting, remove dusts or fluffs stuck on O-ring.
- O-ring and inside of the body shall not be damaged, since there is a possibility of a performance drop by the leakage.
- ※ When a fixing pin is pulled out or inserted, avoid any excessive force on the sensor case. Hold the fixing parts like the right drawing to handle the pins.
- ※ Make sure fixing pins are inserted properly after the replacement of Cartridge Fittings.

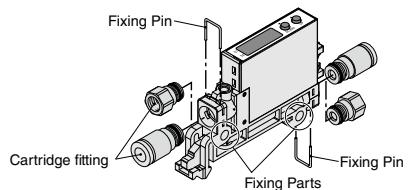

## 8mm width LED Digital Pressure Sensor

## How to insert and disconnect

## 1. How to insert and disconnect tubes

## ① Tube insertion

Insert a tube into Push-In Fitting up to the tube end. Lock-claws bite the tube and fix it automatically, then the elastic sleeve seals around the tube.

Refer to "2. Instructions for Tube Insertion" under "Common Safety Instructions for Fittings".

※ . When a tube is inserted / disconnected while the sensor is mounted on DIN rail, hold and fix the sensor by hand in order to avoid a load on Release Latch.

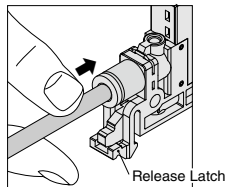

## ② Tube disconnection

The tube is disconnected by pushing release-ring to release Lock-claws.

Make sure to stop air supply before the tube disconnection.

※ . The residual pressure shall be released before the disconnection.

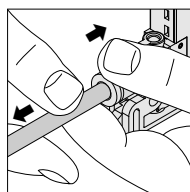

## 2. How to fix body

## ① Fixing by Screw and Bracket

Use 2 fixing holes on the sensor or 2 bracket holes to fix the body with M3 screws. Tighten the screws with tightening torque 0.3-0.5Nm. The product may fall down or be damaged for not using recommended torque range. (Refer to the dimensional drawings of the hole pitch.)

※ . Avoid an excessive vibration or force on the sensor. Otherwise, there is a possibility of damaging it or dropping the performance.

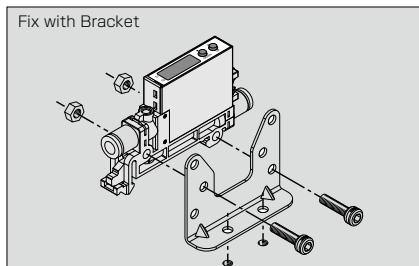
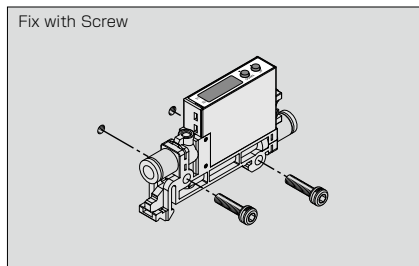

## ② Installing on a DIN rail

## 1. Installation

Place the fixing hook on the edge of DIN rail and push the part indicated with the arrow mark in the drawing below.

※ . Do not push LED display. Otherwise, there is a possibility of damaging the display.

Drawing for Installation

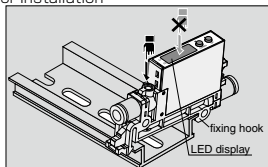

## 2. Detachment

Pull up Release Latch toward the arrowed direction to detach the sensor from DIN rail.

※ . An excessive pulling force may damage the latch.

Drawing for Detachment

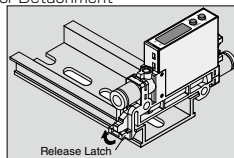

※ . Use DIN rail with a width of 35mm for installation.

※ . When DIN rail is used, attach stoppers (on the market) on both side of DIN rail to install the sensor.

※ . When installing or detaching the sensor from DIN rail, avoid an excessive force on Release Latch. Otherwise, there is a possibility of damaging the latch.

## ■ Applicable Tube and Related Products

### Polyurethane Tube

#### (1. Piping products catalog P.596)

- Polyurethane Tube is for general pneumatic piping and suitable for piping compactly.

### Nylon Tube

#### (1. Piping products catalog P.608)

- Nylon Tube is for general pneumatic piping and suitable for a high-pressure fluid medium up to 1.5MPa (NB tube: 1.0MPa).

### Vacuum Generators . . . . . P.52

- Vacuum Generator changes over from compressed air to vacuum air

## △ Detailed Safety Instructions

Before using PISCO products, be sure to read "Safety Instructions" and "Safety Instruction Manual" on page 35-39, "Common Safety Instructions for Pressure Sensors" on page 794.

### Warning

1. Avoid using the sensor under the condition of corrosive gas. Also do not use the gas as a fluid medium.
2. Avoid using this product in the flammable explosive gas, liquid or ambience. This product is not explosive-proof and may cause fire or explosion under these conditions.
3. Use the product within the described temperature range. Otherwise, there is a possibility of malfunction of the sensor by the heat.
4. Make sure to turn off the power before wiring. Check the wire colors, and do not short-circuit output terminals, power supply terminals and COM terminals when wiring. Short-circuits may cause a sensor trouble.

## 8mm width LED Digital Pressure Sensor

## Caution

1. Supply a stable DC power to the product.
2. Add a surge absorption circuit to relays or solenoid valves, etc. which are to be connected with output terminal and source terminal. Avoid any use which involves over 80mA in current.
3. Ground the FG terminal when using a unit power source such as switching current.
4. Output terminals and other terminals should not be short-circuited.
5. Do not provide loads such as prying force or tensile force between Fitting and sensor case. Keep an enough margin of wire length in order to avoid tensile strength to the sensor. Otherwise, there is a possibility of damaging the joint part between Fitting and the sensor.
6. Wiring or ways by which noise or other disturbance is caused may cause a sensor trouble.
7. Do not give an excessive tensile strength and bending on a lead wire. Otherwise, breaking wire or damage on connector may be caused.
8. Do not press buttons on the sensor with a sharp tip tool. Otherwise, there is a possibility of damaging buttons.
9. Do not press buttons with an excessive force. Otherwise, there is a possibility of damaging buttons or the sensor.
10. Use DIN rail with a width of 35mm for installation.
11. When DIN rail is used, attach stoppers (on the market) on both side of DIN rail to fix the sensor. The sensor may fall off the DIN rail by an excessive vibration and impact.
12. Avoid an excessive force on Release Latch for DIN rail. Otherwise, there is a possibility of damaging the latch. Especially when a tube is inserted / disconnected while the sensor is installed on DIN rail, hold and fix the sensor by hand in order to avoid load on Release Latch.
13. A protection film is on the LED display. Remove the film when necessary.
14. A cartridge fitting is removable by pulling out a fixing pin, but make sure that the pin is inserted properly while the sensor is in operation.
15. Keep the product away from water/oil drops or dusts, since it is not drip/dust proof structure. Otherwise, there is a possibility of the sensor malfunction.
16. When other equipment is connected to the power supply which also applies the power to the sensor, and if switch output terminals are short-circuited with the negative side by a switch of load operation test while the negative side (COM) is shut off, a reverse electric current flows in to the switch output circuit and damages the sensor. In order to prevent this problem, place backflow prevention diode on the power supply wire of the negative side or on the switch output wire toward the direction which is indicated on the drawing below.

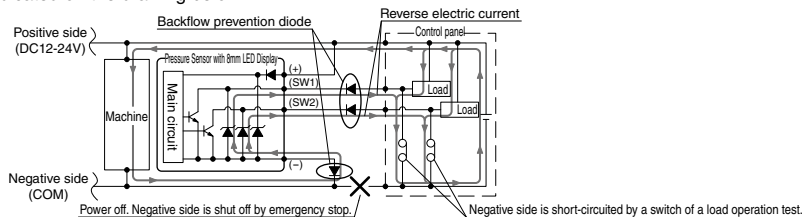

## VUS Single Port / Push-In Fitting

RoHS compliant

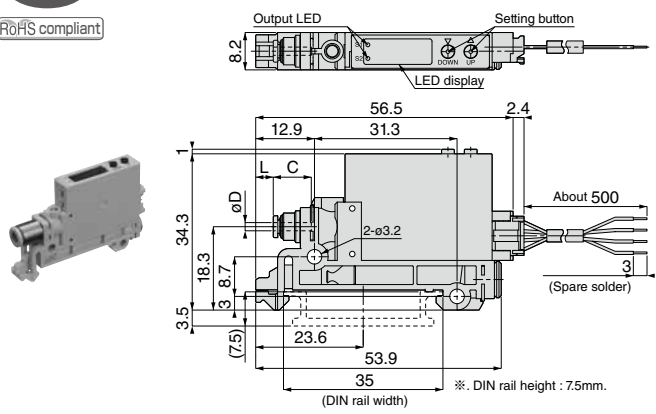

Unit : mm

Model code	Tube O.D. øD	L	C	Weight (g)	CAD file name
VUS8-180-□	1.8	3.9	8.4	17	—
VUS8-3-□	3	-	12.9	18	
VUS8-4-□	4	-	10.9	18	

## VUS Single Port / Bracket / Push-In Fitting

RoHS compliant

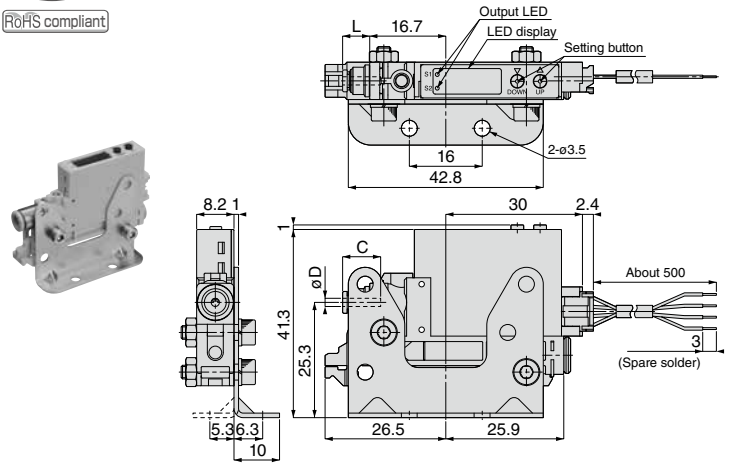

Unit : mm

Model code	Tube O.D. øD	L	L	Weight (g)	CAD file name
VUS8-180-□-B	1.8	6	8.4	30	—
VUS8-3-□-B	3	9.8	12.9	31	
VUS8-4-□-B	4	9.8	10.9	31	

## 8mm width LED Digital Pressure Sensor

VACUUM GENERATOR  
VACUUM CONTROLLER  
EXTERNAL VACUUM CONTROLLER  
VACUUM PAD  
VACUUM ACCESSORIES

### VUS Single Port / Without Bracket / Female Thread

RoHS compliant

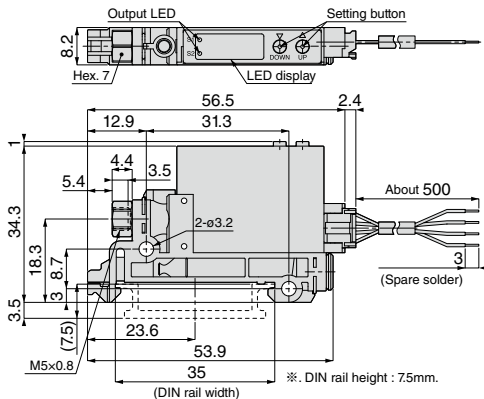

Unit : mm

Model code	Weight (g)	CAD file name
VUS8-M5-□	17	—

### VUS Single Port / With Bracket / Female Thread

RoHS compliant

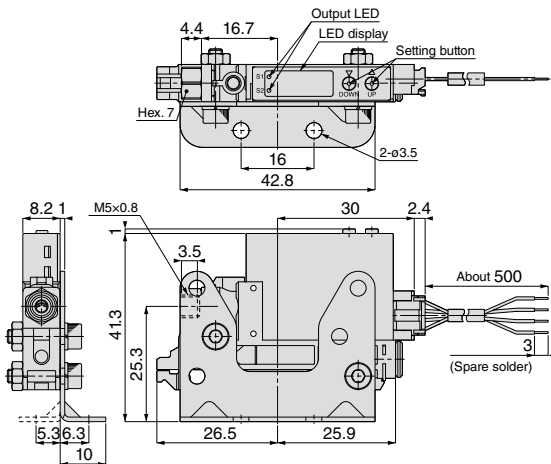

Unit : mm

Model code	Weight (g)	CAD file name
VUS8-M5-□-B	30	—

Small Vacuum Regulator  
Adion Box of Controller  
Vacuum Filter  
Free Holder  
Fast Protection Valve  
8mm LED Pressure Sensor

## VUS Inline Port / Without Bracket / Push-In Fitting

RoHS compliant

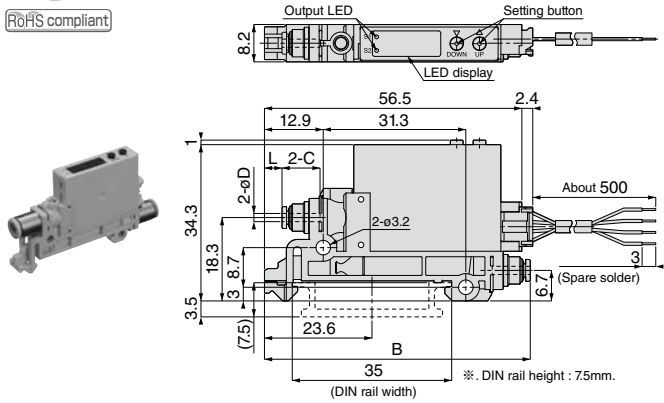

Unit : mm

Model code	Tube O.D. φD	B	L	C	Weight (g)	CAD file name
VUS8-180180-□	1.8	58.4	3.9	8.4	18	—
VUS8-33-□	3	62.2	-	12.9	20	
VUS8-44-□	4	62.2	-	10.9	20	

## VUS Inline Port / With Bracket / Push-In Fitting

RoHS compliant

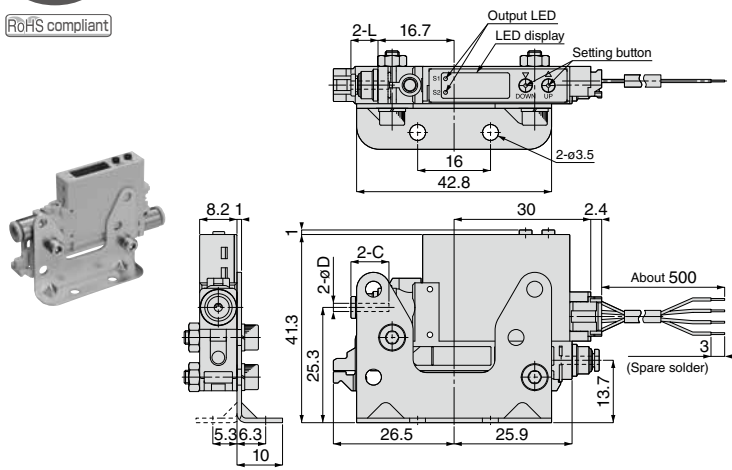

Unit : mm

Model code	Tube O.D. φD	L	C	Weight (g)	CAD file name
VUS8-180180-□-B	1.8	6	8.4	31	—
VUS8-33-□-B	3	9.8	12.9	33	
VUS8-44-□-B	4	9.8	10.9	33	

## 8mm width LED Digital Pressure Sensor

VACUUM GENERATOR  
EXTERNAL VACUUM CONTROLLER  
VACUUM PAD  
VACUUM ACCESSORIES

### VUS Inline Port / Without Bracket / Female Thread

RoHS compliant

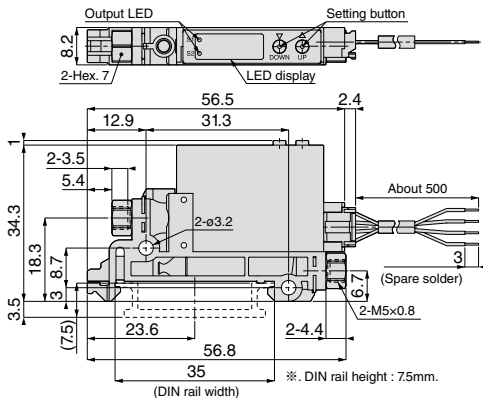

Unit : mm

Model code	Weight (g)	CAD file name
VUS8-M5M5-□	18	—

### VUS Inline Port / With Bracket / Female Thread

RoHS compliant

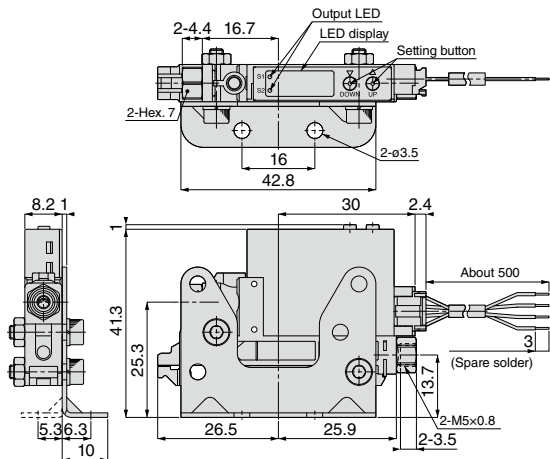

Unit : mm

Model code	Weight (g)	CAD file name
VUS8-M5M5-□-B	31	—





# SAFETY Instructions

This safety instructions aim to prevent personal injury and damage to properties by requiring proper use of PISCO products.

Be certain to follow ISO 4414 and JIS B 8370

ISO 4414 : Pneumatic fluid power...Recommendations for the application of equipment to transmission and control systems.

JIS B 8370 : General rules and safety requirements for systems and their components.

This safety instructions is classified into "Danger", "Warning" and "Caution" depending on the degree of danger or damages caused by improper use of PISCO products.



**Danger**

Hazardous conditions. It can cause death or serious personal injury.



**Warning**

Hazardous conditions depending on usages. Improper use of PISCO products can cause death or serious personal injury.



**Caution**

Hazardous conditions depending on usages. Improper use of PISCO products can cause personal injury or damages to properties.



## Warning

### 1. Selection of pneumatic products

- ① A user who is a pneumatic system designer or has sufficient experience and technical expertise should select PISCO products.
- ② Due to wide variety of operating conditions and applications for PISCO products, carry out the analysis and evaluation on PISCO products. The pneumatic system designer is solely responsible for assuring that the user's requirements are met and that the application presents no health or safety hazards. All designers are required to fully understand the specifications of PISCO products and constitute all systems based on the latest catalog or information, considering any malfunctions.

### 2. Handle the pneumatic equipment with enough knowledge and experience

- ① Improper use of compressed air is dangerous. Assembly, operation and maintenance of machines using pneumatic equipment should be conducted by a person with enough knowledge and experience.

### 3. Do not operate machine / equipment or remove pneumatic equipment until safety is confirmed.

- ① Make sure that preventive measures against falling work-pieces or sudden movements of machine are completed before inspection or maintenance of these machine.
- ② Make sure the above preventive measures are completed. A compressed air supply and the power supply to the machine must be off, and also the compressed air in the systems must be exhausted.
- ③ Restart the machines with care after ensuring to take all preventive measures against sudden movements.

## Disclaimer

1. PISCO does not take any responsibility for any incidental or indirect loss, such as production line stop, interruption of business, loss of benefits, personal injury, etc., caused by any failure on use or application of PISCO products.
2. PISCO does not take any responsibility for any loss caused by natural disasters, fires not related to PISCO products, acts by third parties, and intentional or accidental damages of PISCO products due to incorrect usage.
3. PISCO does not take any responsibility for any loss caused by improper usage of PISCO products such as exceeding the specification limit or not following the usage the published instructions and catalog allow.
4. PISCO does not take any responsibility for any loss caused by remodeling of PISCO products, or by combinational use with non-PISCO products and other software systems.
5. The damages caused by the defect of Pisco products shall be covered but limited to the full amount of the PISCO products paid by the customer.



# SAFETY INSTRUCTION MANUAL

PISCO products are designed and manufactured for use in general industrial machines. Be sure to read and follow the instructions below.

## Danger

1. Do not use PISCO products for the following applications.
  - ① Equipment used for maintaining / handling human life and body.
  - ② Equipment used for moving / transporting human.
  - ③ Equipment specifically used for safety purposes.

## Warning

1. Do not use PISCO products under the following conditions.
  - ① Beyond the specifications or conditions stated in the catalog, or the instructions.
  - ② Under the direct sunlight or outdoors.
  - ③ Excessive vibrations and impacts.
  - ④ Exposure / adhere to corrosive gas, inflammable gas, chemicals, seawater, water and vapor. \*
    - \* Some products can be used under the condition above(④), refer to the details of specification and condition of each product.
2. Do not disassemble or modify PISCO products, which affect the performance, function, and basic structure of the product.
3. Turn off the power supply, stop the air supply to PISCO products, and make sure there is no residual air pressure in the pipes before maintenance and inspection.
4. Do not touch the release-ring of push-in fitting when there is a working pressure. The lock may be released by the physical contact, and tube may fly out or slip out.
5. Frequent switchover of compressed air may generate heat, and there is a risk of causing burn injury.
6. Avoid any load on PISCO products, such as a tensile strength, twisting and bending. Otherwise, there is a risk of causing damage to the products.
7. As for applications where threads or tubes swing / rotate, use Rotary Joints, High Rotary Joints or Multi-Circuit Rotary Block only. The other PISCO products can be damaged in these applications.
8. Use only Die Temperature Control Fitting Series, Tube Fitting Stainless SUS316 Series, Tube Fitting Stainless SUS316 Compression Fitting Series or Tube Fitting Brass Series under the condition of over 60°C (140° F) water or thermal oil. Other PISCO products can be damaged by heat and hydrolysis under the condition above.
9. As for the condition required to dissipate static electricity or provide an antistatic performance, use EG series fitting and antistatic products only, and do not use other PISCO products. There is a risk that static electricity can cause system defects or failures.
10. Use only Fittings with a characteristic of spatter-proof such as Anti-spatter or Brass series in a place where flame and weld spatter is produced. There is a risk of causing fire by sparks.
11. Turn off the power supply to PISCO products, and make sure there is no residual air pressure in the pipes and equipment before maintenance. Follow the instructions below in order to ensure safety.
  - ① Make sure the safety of all systems related to PISCO products before maintenance.
  - ② Restart of operation after maintenance shall be proceeded with care after ensuring safety of the system by preventive measures against unexpected movements of machines and devices where pneumatic equipment is used.
  - ③ Keep enough space for maintenance when designing a circuit.
12. Take safety measures such as providing a protection cover if there is a risk of causing damages or fires on machine / facilities by a fluid leakage.

### ⚠ Caution

1. Remove dusts or drain before piping. They may get into the peripheral machine / facilities and cause malfunction.
2. When inserting an ultra-soft tube into push-in fitting, make sure to place an Insert Ring into the tube edge. There is a risk of causing the escape of tube and a fluid leakage without using an Insert Ring.
3. The product incorporating NBR as seal rubber material has a risk of malfunction caused by ozone crack. Ozone exists in high concentrations in static elimination air, clean-room, and near the high-voltage motors, etc. As a countermeasure, material change from NBR to HNBR or FKM is necessary. Consult with PISCO for more information.
4. Special option "Oil-free" products may cause a very small amount of a fluid leakage. When a fluid medium is liquid or the products are required to be used in harsh environments, contact us for further information.
5. In case of using non-PISCO brand tubes, make sure the tolerance of the outer tube diameter is within the limits of Table 1.

● Table 1. Tube O.D. Tolerance

mm size	Nylon tube	Polyurethane tube	inch size	Nylon tube	Polyurethane tube
ø1.8mm	—	± 0.05mm	ø1/8	± 0.1mm	± 0.15mm
ø3mm	—	± 0.15mm	ø5/32	± 0.1mm	± 0.15mm
ø4mm	± 0.1mm	± 0.15mm	ø3/16	± 0.1mm	± 0.15mm
ø6mm	± 0.1mm	± 0.15mm	ø1/4	± 0.1mm	± 0.15mm
ø8mm	± 0.1mm	± 0.15mm	ø5/16	± 0.1mm	± 0.15mm
ø10mm	± 0.1mm	± 0.15mm	ø3/8	± 0.1mm	± 0.15mm
ø12mm	± 0.1mm	± 0.15mm	ø1/2	± 0.1mm	± 0.15mm
ø16mm	± 0.1mm	± 0.15mm	ø5/8	± 0.1mm	± 0.15mm

### 6. Instructions for Tube Insertion

- ① Make sure that the cut end surface of the tube is at right angle without a scratch on the surface and deformations.
- ② When inserting a tube, the tube needs to be inserted fully into the push-in fitting until the tubing edge touches the tube end of the fitting as shown in the figure below. Otherwise, there is a risk of leakage.

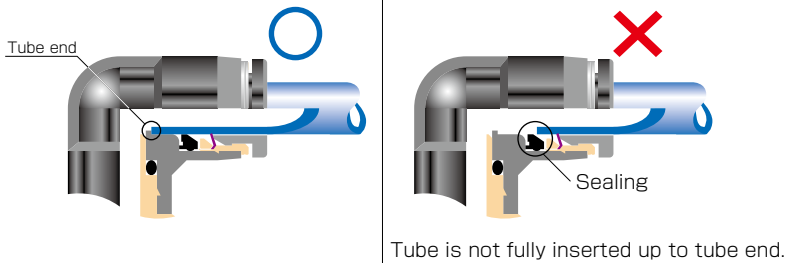

- ③ After inserting the tube, make sure it is inserted properly and not to be disconnected by pulling it moderately.
- ※ When inserting tubes, Lock-claws may be hardly visible in the hole, observed from the front face of the release-ring. But it does not mean the tube will surely escape. Major causes of the tube escape are the followings;
  - ① Shear drop of the lock-claws edge
  - ② The problem of tube diameter (usually small)
 Therefore, follow the above instructions from ① to ③, even lock-claws is hardly visible.

## 7. Instructions for Tube Disconnection

- ① Make sure there is no air pressure inside of the tube, before disconnecting it.
- ② Push the release-ring of the push-in fitting evenly and deeply enough to pull out the tube toward oneself. By insufficient pushing of the release-ring, the tube may not be pulled out or damaged by scratch, and tube shavings may remain inside of the fitting, which may cause the leakage later.

## 8. Instructions for Installing a fitting

- ① When installing a fitting, use proper tools to tighten a hexagonal-column or an inner hexagonal socket. When inserting a hex key into the inner hexagonal socket of the fitting, be careful so that the tool does not touch lock-claws. The deformation of lock-claws may result in a poor performance of systems or an escape of the tube.
- ② Refer to Table 2 which shows the recommended tightening torque. Do not exceed these limits to tighten a thread. Excessive tightening may break the thread part or deform the gasket and cause a fluid leakage. Tightening thread with tightening torque lower than these limits may cause a loosened thread or a fluid leakage.
- ③ Adjust the tube direction while tightening thread within these limits, since some PISCO products are not rotatable after the installation.

- Table 2: Recommended tightening torque / Sealock color / Gasket materials

Thread type	Thread size	Tightening torque	Sealock color	Gasket materials
Metric thread	M3 × 0.5	0.7N·m	—	SUS304 NBR
	M5 × 0.8	1.0 ~ 1.5N·m		
	M6 × 1	2 ~ 2.7N·m		
	M3 × 0.5	0.7N·m		POM
	M5 × 0.8	1 ~ 1.5N·m		
	M6 × 0.75	0.8 ~ 1N·m		
Taper pipe thread	M8 × 0.75	1 ~ 2N·m	White	—
	R1/8	4.5 ~ 6.5N·m		
	R1/4	7 ~ 9N·m		
	R3/8	12.5 ~ 14.5N·m		
Unified thread	R1/2	20 ~ 22N·m	—	SUS304, NBR
	No.10-32UNF	1.0 ~ 1.5N·m		
National pipe thread taper	1/16-27NPT	4.5 ~ 6.5N·m	White	—
	1/8-27NPT	4.5 ~ 6.5N·m		
	1/4-18NPT	7 ~ 9N·m		
	3/8-18NPT	12.5 ~ 14.5N·m		
	1/2-14NPT	20 ~ 22N·m		

※ These values may differ for some products. Refer to each specification as well.

## 9. Instructions for removing a fitting

- ① When removing a fitting, use proper tools to loosen a hexagonal-column or an inner hex bolt.
- ② Remove the sealant stuck on the mating equipment. The remained sealant may get into the peripheral equipment and cause malfunctions.

## 10. Arrange piping avoiding any load on fittings and tubes such as twist, tensile, moment load, shaking and physical impact. These may cause damages to fittings, tube deformations, bursting and the escape of tubes.

## Common Safety Instructions for Pressure Sensors

Before selecting or using PISCO products, read the following information. Regarding the instructions of each series, please follow each Detailed Safety Instructions.

### Warning

1. Avoid an excessive tensile strength, twisting force, bending, dropping and strong impact on pressure sensors. Otherwise, there is a possibility of damaging the products.
2. Supply clean air to the operating pressure source. There is a possibility of malfunction of sensors by sludge or dusts.

### Caution

1. Refer to “Common Safety Instructions for Fittings” for handling Fittings.
2. Instructions for Installation
  - ①. Use a proper tool to tighten hexagonal-columns of body.
  - ②. Refer to the following recommended tightening torque to tighten thread. Do not exceed these limits to tighten a thread. Excessive tightening may break the thread part or deform the gasket to cause a fluid leakage. Tightening thread with tightening torque less than these limits may cause a loosened thread or fluid leakage.

● Table: Recommended tightening torque (Hexagonal-column)

Thread type	Thread size	Tightening torque
Metric thread	M5×0.8	1.5 ~ 1.9N·m
Taper pipe thread	R1/8	7 ~ 9N·m

### 3. Instructions for Removal

- ①. Use a proper tool to tighten hexagonal-columns of body.
- ②. Remove the sealant stuck on the mating equipment. The remained sealant may get into the peripheral equipment and cause malfunctions.