

Order example

MCHS – 50

MODEL

BODY SPECIFICATION
50, 66, 80, 100,
125, 160, 200, 300

Features

- Compact design to ensure minimum interference while operating; robust T rail design, ensure accurate gripping.
- Can reach maximum torque suitable for long jaws design.
- Oval piston-driven design ensure maximum gripping force.
- Hose-free direct connection: Air supply channel can connect directly without piping or through thread to assure the flexibility of supplying compressed air on any kind of automation system.

Specification

Model	MCHS							
Acting type	Double acting							
Body specification	50	66	80	100	125	160	200	300
Stroke per-jaw(mm)	4	6	8	10	12	16	20	30
Closing force(N)	170	300	550	740	1290	1860	3175	6675
Opening force(N)	185	325	590	795	1370	1960	3330	6830
Close/Open time(s)	0.02	0.03	0.04	0.07	0.1	0.1	0.35	0.4
Medium	Air							
Operating pressure range	0.3~0.8 MPa							
Compressed air consumption(cm ³)	4.1	10.1	23.6	39.3	85	85	330	1000
Ambient temperature	+5°C~ +80°C							
Lubrication	Not required							
Sensor switch (*)	2 wire	RDFE(V): Non-contact						
	3 wire	RNFE(V): NPN, RPFV(V): PNP						
Proximity sensor	RDP8 (2 wire), RNP8 (3 wire)							
Accessories	Mounting block, Centering sleeve							
Weight (kg)	0.14	0.27	0.495	0.85	1.6	3.0	5.7	14.2
Recom. workpiece weight (kg)	0.85	1.4	2.6	3.6	6.3	9.2	15	32

* R*FE(V) specification, please refer to page 5-10.

Installation of sensor switch & speed controller

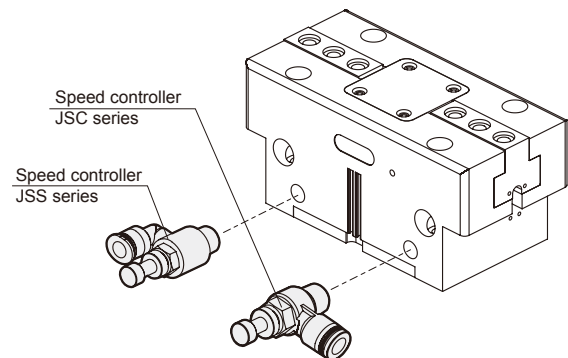
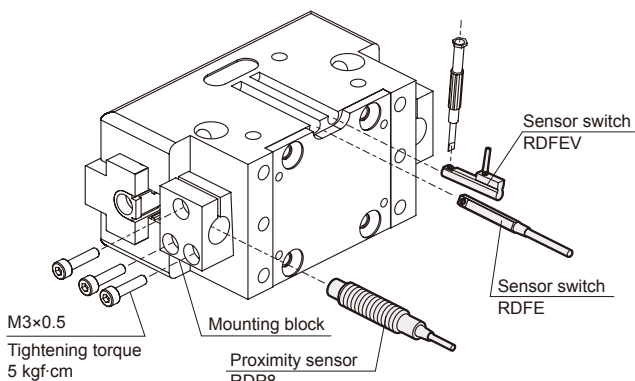

* Each gripper needs at least two speed control valves to control speed.
* Speed controller specification, please refer to page 8-15~17 (Vol.1).

Holding force

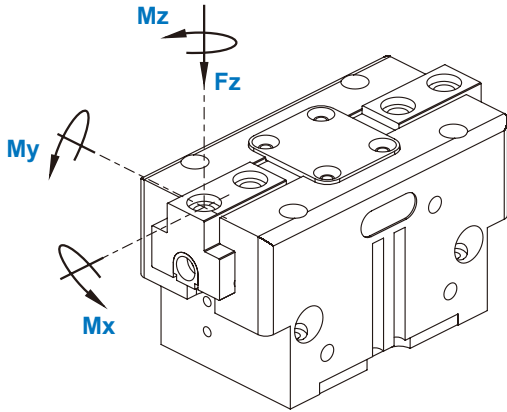

Code Model	Mx max. (Nm)	My max. (Nm)	Mz max. (Nm)	Fz max. (N)
MCHS-50	15	15	8	700
MCHS-66	50	45	35	1200
MCHS-80	80	60	50	1800
MCHS-100	100	90	75	2500
MCHS-125	120	120	100	3200
MCHS-160	160	180	140	5000
MCHS-200	180	220	170	7000
MCHS-300	275	300	200	9000

MCHS-50

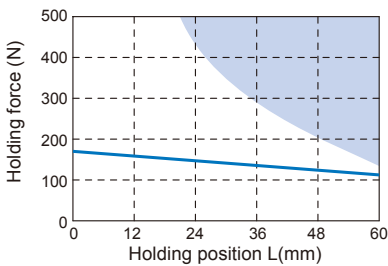

MCHS-66

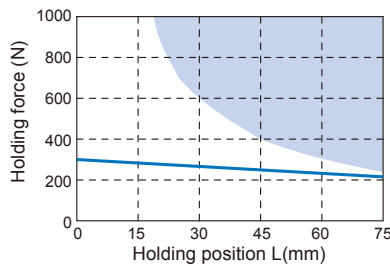

MCHS-80

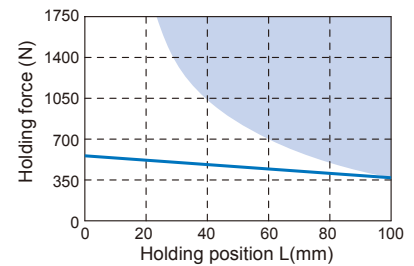

MCHS-100

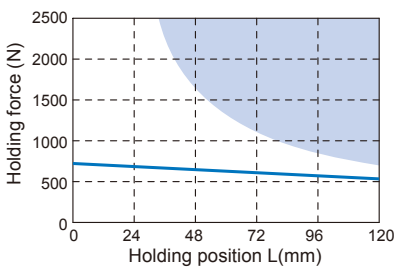

MCHS-125

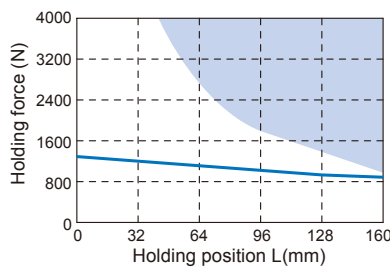

MCHS-160

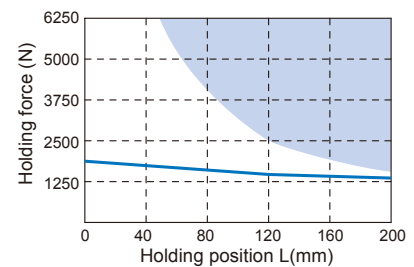

MCHS-200

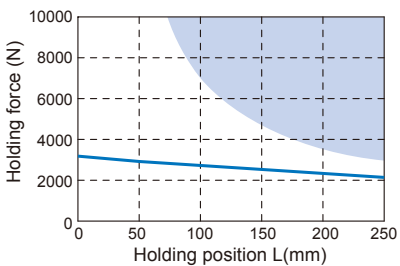

MCHS-300

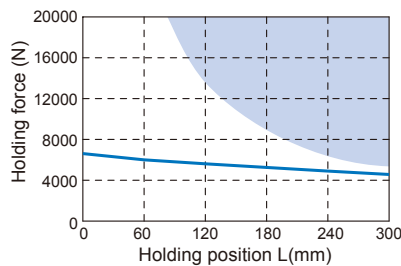

* Blue area: Less durable performance can be expected.

Max. feasible centrifugal degree

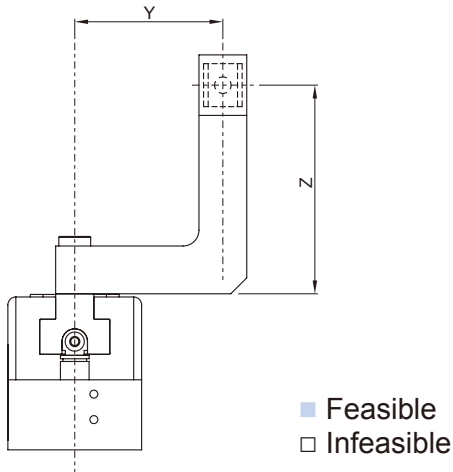

MCHS-50

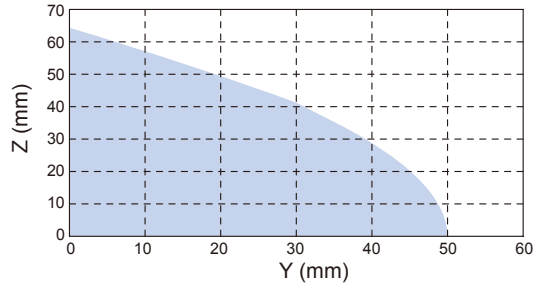

MCHS-66

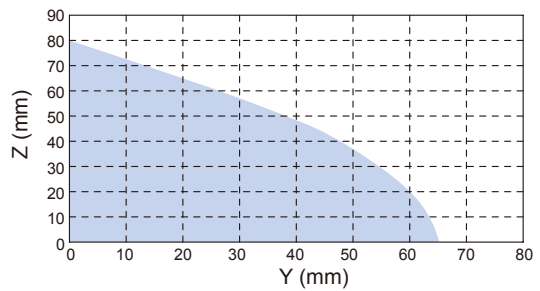

MCHS-80

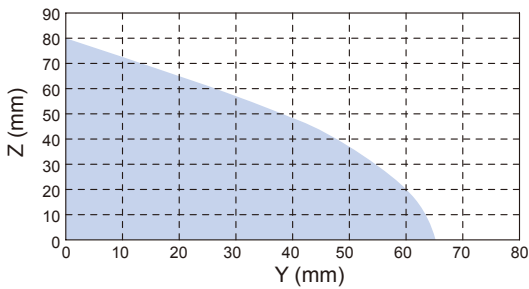

MCHS-100

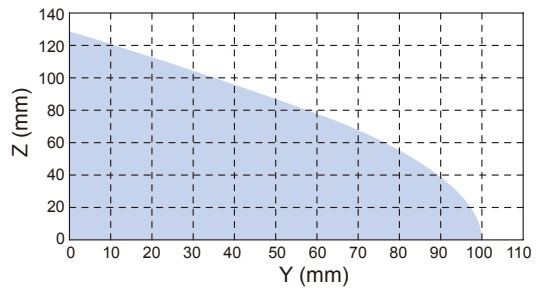

MCHS-125

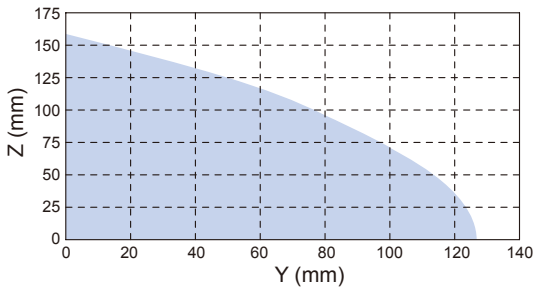

MCHS-160

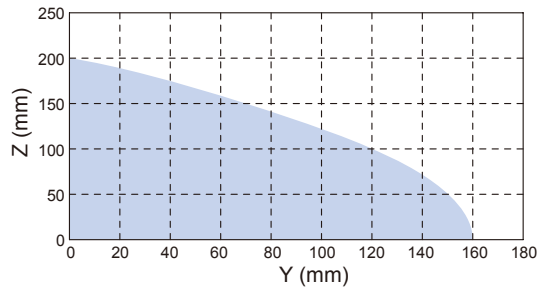

MCHS-200

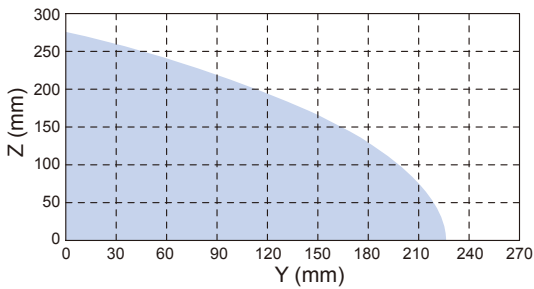

MCHS-300

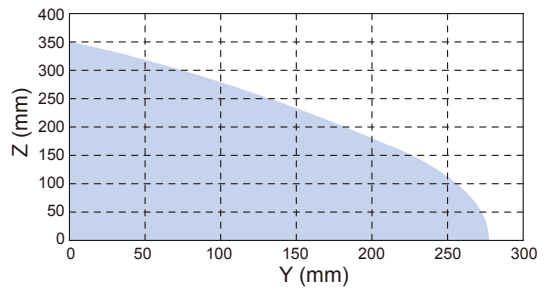

Internal structure & Movement description

Compressed air will push or press the oval piston.
By tilting the working surface, the wedge hook will transfer the movement to side movement, and initiate the action of the two base jaws simultaneously.

Rail

Bearing rails load the base jaw, which ensure the minimal vibration of long jaw.

Material

Anodized high rigid aluminum alloy to reduce weight.

Base jaw

Jaws connected to work piece.

Large oval piston

Generate larger structural strength.

Wedge hook

High power transmission center jaws.

Sensor system

Sensor switch or proximity sensor are available.

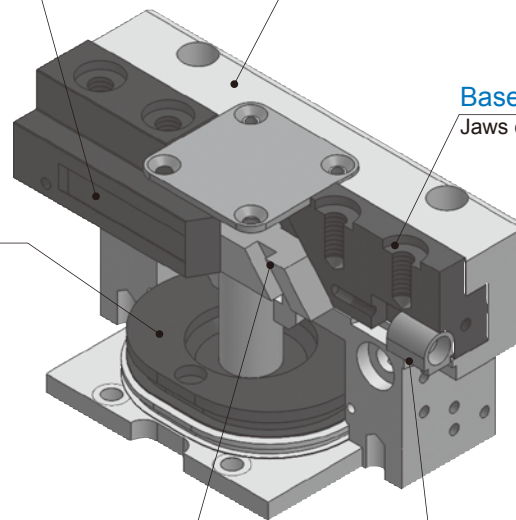

Application examples

Hose-free direct connection

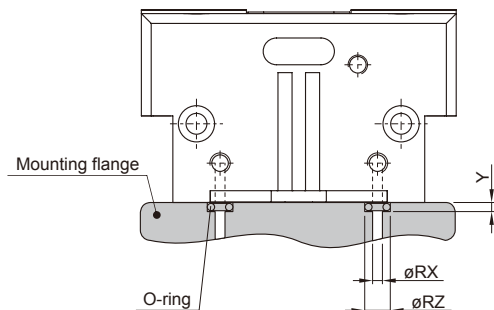
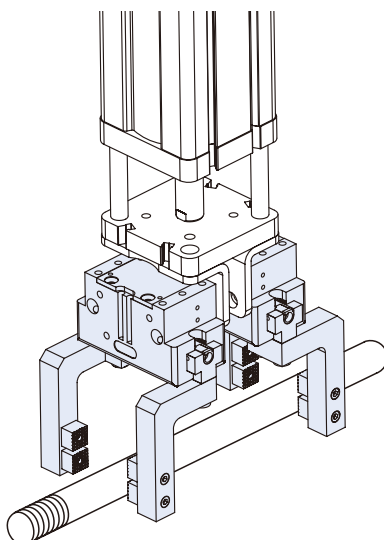

Code Model	R	RX	RZ	Y
50	M2	2	4	0.7
66	M3	3	5	0.7
80	M3	3	5	1.1
100	M5	5	8	1.1
125	M5	5	8	1.1
160	M5	5	8	1.1
200	M5	5	8	1.1
300	M5	5	8	1.1

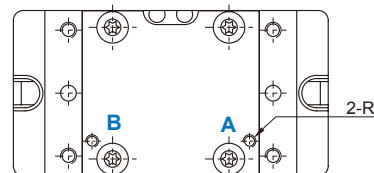

A : Gripper open
B : Gripper close

PARALLEL GRIPPER (2-Finger)

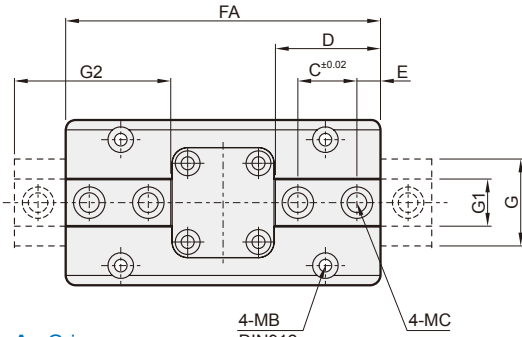

A : Gripper open
 B : Gripper close
 S : External vents

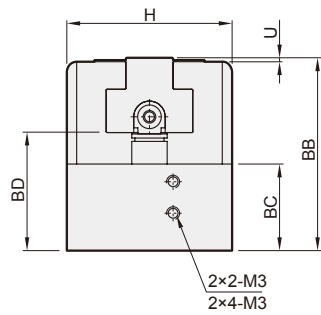
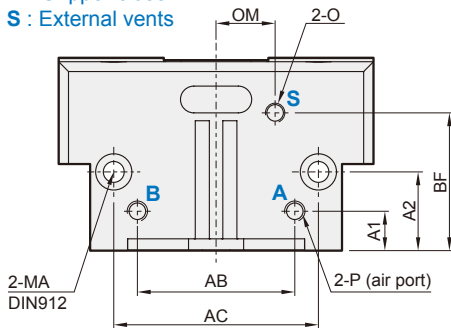

* Only for MCHS-100

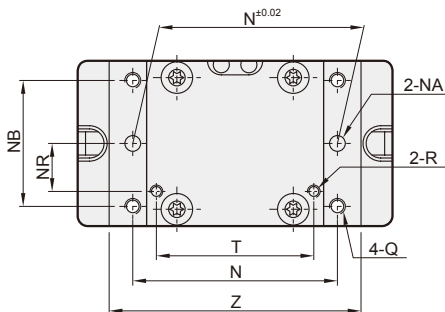
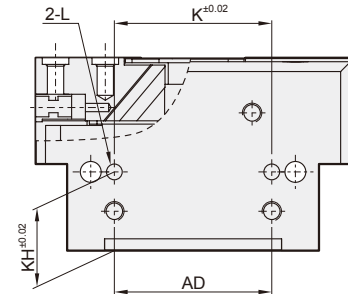

Centering sleeve

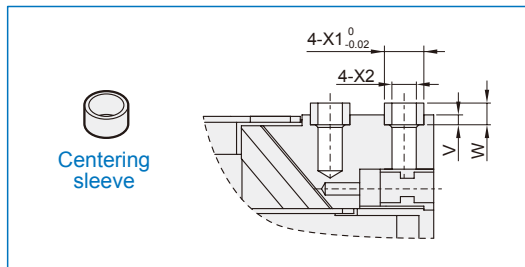

Code Model	A1	A2	AB	AC	AD	BB	BC	BD	BF	C	D	E	FA	G	G1	G2	H	K	KH	L
MCHS-50	5	15	25	35	25	31	15	19	22	8	16	4	50	12	6.5	20	27.8	25	15	ø3H7×4.5dp
MCHS-66	5	18	28	42	28	39	18.5	23	27.5	12	22	5	64	17	10	28	36	20	18	ø4H7×4dp
MCHS-80	10	20	40	52	40	49	22	30	35	15	26.7	6	80	22	12	34.7	42	40	20	ø4H7×6dp
MCHS-100	12	25	48	66	54	55	28	33	38	18	34.3	10	100	26	14	44.3	50	50	25	ø5H7×7dp

Code Model	MA	MB	MC	N	NA	NB	NR	O	OM	P	Q	R	T	U	V	W	X1	X2	Z
MCHS-50	M3	M3	M3	35	ø3H7	20	8	M3	10	M5	M4	M2	25	1	2	4	ø5	ø3	42
MCHS-66	M4	M4	M4	42	ø4H7	27	11	M5	12	M5	M5	M3	28	1	2	4	ø6	ø4	52
MCHS-80	M4	M4	M6	52	ø4H7	32	12.2	M5	15	M5	M5	M3	40	1	2	4	ø8	ø6	64
MCHS-100	M5	M5	M6	66	ø5H7	38	16	M5	16	G1/8	M6	M5	48	1	2	4	ø10	ø6	80

PARALLEL GRIPPER (2-Finger)

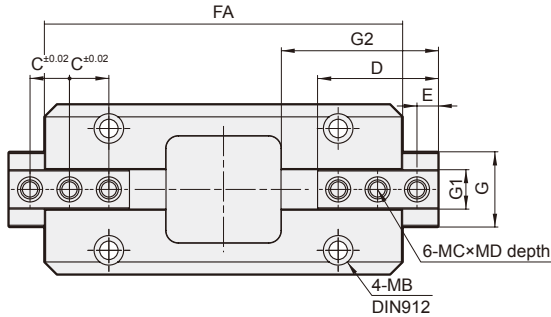

- A : Gripper open
- B : Gripper close
- S : External vents

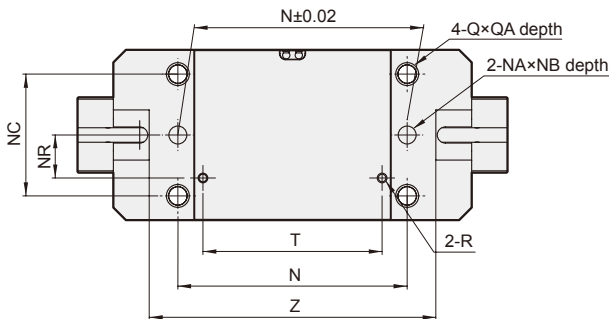
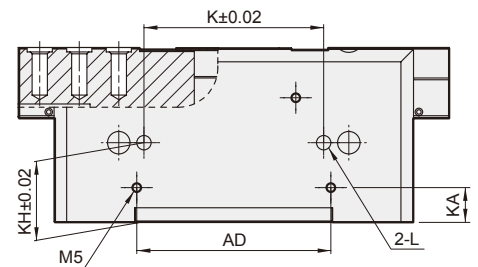
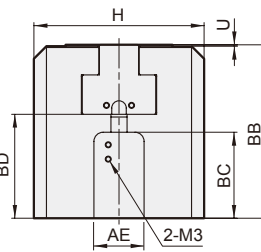
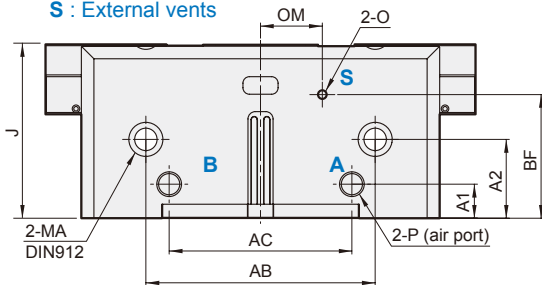

Centering sleeve

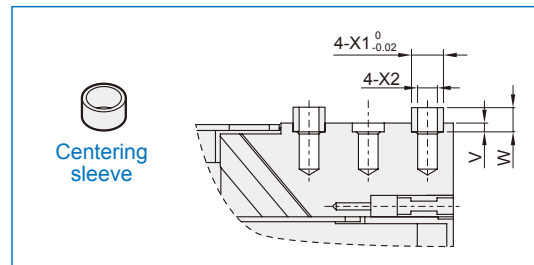

Code Model	A1	A2	AB	AC	AD	AE	BB	BC	BD	BF	C	D	E	FA	G	G1	G2	H	J	K	KA	KH	L
MCHS-125	13	30	82	62	65.5	22	63	32	38.5	45	12.5	42.3	10	125	31	15.5	54.3	60	64	60	13	30	ø6H7×8dp
MCHS-160	15.5	28	100	78	82	26	77	39	46	53	18	54.8	10	160	39	20	70.8	72	78	76	15.5	28	ø6H7×10dp
MCHS-200	19	44	128	102	108	28	96	48	58	69	22	67.5	12	200	42	22	87.5	95	97	100	19	44	ø8H7×8dp
MCHS-300	19	66	180	150	152	30	128	67	78	92	30	91.0	15	260	66	32	121	139	130	140	19	66	ø10H7×12dp

Code Model	MA	MB	MC	MD	N	NA	NB	NC	NR	O	OM	P	Q	QA	R	T	U	V	W	X1	X2	Z
MCHS-125	M8	M6	M6	14	82	ø6H7	8	45	17.7	M5	20	G1/8	M8	12	M5	60	0.8	2	3.9	ø10h7	ø6.5	100
MCHS-160	M8	M6	M8	17	100	ø6H7	8	56	22	M5	27	G1/8	M8	12	M5	76	0.8	2	3.9	ø12h7	ø8.5	125
MCHS-200	M12	M10	M10	20	128	ø10H7	10	68	24	M5	34.5	G1/4	M12	17	M5	100	0.8	2.5	4.9	ø14h7	ø11	160
MCHS-300	M12	M10	M12	20	180	ø10H7	12	100	24	M5	43	G1/4	M12	16	M5	150	0.8	2.5	4.9	ø18h7	ø12.5	220