

- Used extensively for providing smooth consistent feed speed on machine tools.
- Construction incorporates double seal enabling unit to be used in dirty and dusty environments.
- Fully adjustable speeds can be quickly and simply selected.
- Compact size, ideal for use on robots, drills, conveyors, cut off machines and woodworking equipment.
- Can be used in conjunction with Pneumatic air cylinder in order to provide consistent movement.

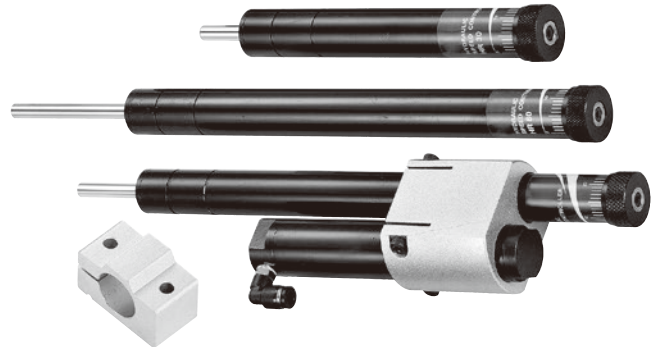

Specification

Order no.	Max. stroke (mm)	A	B	Operating temperature (°C)	Max. load (kgf)	Weight (g)
MHR-15	15 mm	152	137	0-60	15~350	470
MHR-30	30 mm	202	172	0-60	15~350	495
MHR-60	60 mm	282.5	222.5	0-60	15~350	615
MHR-80	80 mm	350	270	0-60	15~350	690
MHR-100	100 mm	396	296	0-60	15~350	765
MHR-3160	60 mm	331	271	0-60	30~420	1000
MHRT-60	60 mm	317	258	0-60	15~350	1555
MHRT-100	100 mm	389.5	289.5	0-60	15~350	1635

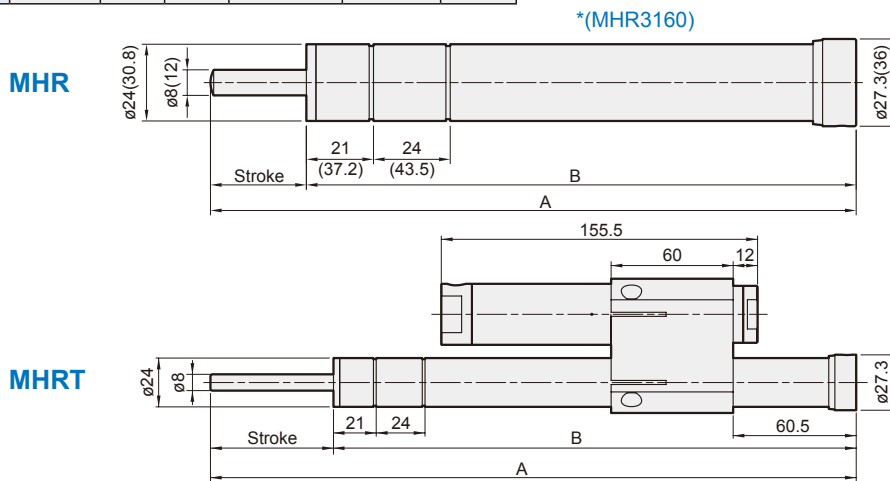
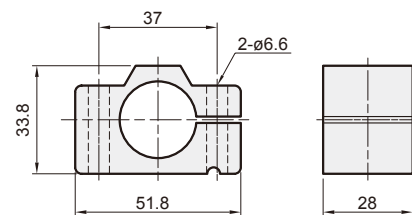

Application example

