

# P15

## 15 mm COMPACT valves - threaded body and for sub-base mounting 90° ELECTROPILOT CONNECTION

- Standard consumption: 1W; upon request low power consumption: 0,3W
- Quick response times
- High flow rate: the development of the traditional UNIVER spool technology permits high flow rate values
- Compact design: the valve body (15 mm) allows reduced overall dimensions
- Complete solution
- Threaded body (P15F) and body for sub-base (P15B) in the following versions: 5/2 - 5/3 - 3/2+3/2
- External and multipolar electrical connections
- TC serial transmission system
- Maximum application flexibility
- Modular sub-base (singles and doubles) for a high versatility in the composition of valve manifolds
- Simplified installation
- Easy installation of tubes and fittings thanks to connections being all on the same side

Available ATEX version upon request

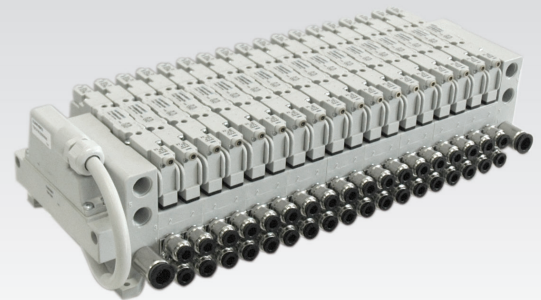

### TECHNICAL CHARACTERISTICS

Ambient temperature	-5 ÷ +50 °C
Fluid temperature	Max +50 °C
Fluid	10 µm filtered air, with or without lubrication
Commutation system	spool
Ways/Positions	3/2+3/2, 5/2, 5/3
Pressure	electric control = Max 9 bar * pneumatic control = Max 10 bar
Control	indirect electro-pneumatic, pneumatic
Return	mechanical spring, pneumomechanical spring
Connections	G1/8 (P15F) - G1/8 tubo Ø 4-6-8 (P15B)
Nominal flow rate (NI/min)	800 (5/2) 720 (5/3) 720 (3/2+3/2)

### CONSTRUCTIVE CHARACTERISTICS

Valve body	zamak
Seals	nitrile rubber (NBR)
Sub-base and actuators	selfextinguishing technopolymer
Spool	aluminum

### ELECTRIC CHARACTERISTICS

Electropilot	B10 (0,3 W) B11 (1 W)
Voltage	24 V DC (± 10%)
Power consumption	B10 = 0,3 W, speed -up 1 W (25 ms) B11 = 1 W
Protection degree	IP65
Manual override	recessed button - 1 position

### CODIFICATION KEY

P	1	5	F	2	4	4	2	4		
	1			2	3	4	5	6	7	

1 Series	2 Type	3 Control 14	4 Return 12
P15F = threaded body P15B = Body for sub-base P15D = Threaded body 15 mm connector	2 = 5/2 3 = 5/3 c.c. 4 = 5/3 o.c. 5 = 5/3 p.c.	6 = 3/2+3/2 NC-NC 7 = 3/2+3/2 NC-NO 8 = 3/2+3/2 NO-NO	0 = pneumomechanical spring 1 = mechanical spring 3 = pneumatic amplified 4 = electric amplified 90° (0,3W) 6 = electric amplified 90° (1W)

o.c. = open centres c.c. = closed centres p.c. = pressurized centres

5 Voltage	6 Variant	7 ATEX option
24 = 24 V DC	D = external pilot supply on valve body (P15 = M5)	X = Atex (upon request) See ATEX Catalogue for types and versions

Version with in-line connections  
(upon request)

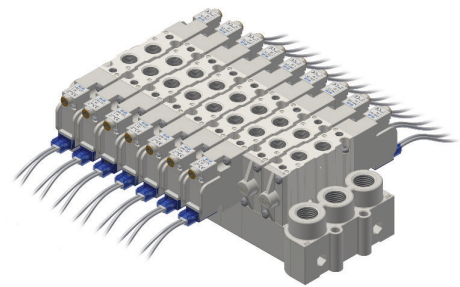

### Single electric impulse



Weight (Kg): 0,138

	Symbol	Control	Return	Pressure bar	Resp. Time (ms)		Part no.
					En.	De-en.	
5/2		14 electric amplified	12 pneumo mechanical spring	1,9÷9	15	24	P15F24024 P15F26024
5/2		14 electric amplified	12 mechanical spring	2÷9	12	21	P15F24124 P15F26124

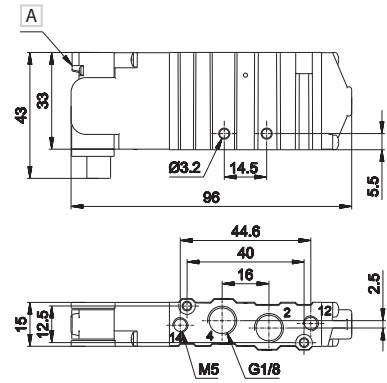

A Manual override

2 - 4 = Use  
14 = Control  
12 = Return

### Double electric impulse



Weight (Kg): 0,158

	Symbol	Control	Return	Pressure bar	Resp. Time (ms)		Part no.
					En.	De-en.	
5/2		14 electric amplified	12 electric amplified	0,7÷9	11	11	P15F24424 P15F26624
5/3 c.c.		14 electric amplified	12 electric amplified	1,6÷9	11	35	P15F34424 P15F36624
5/3 o.c.		14 electric amplified	12 electric amplified	1,6÷9	11	35	P15F44424 P15F66624
5/3 p.c.		14 electric amplified	12 electric amplified	1,6÷9	11	35	P15F54424 P15F56624
3/2 NC + 3/2 NC		14 electric amplified	12 electric amplified	1,5÷9	14	16	P15F64424 P15F66624
3/2 NC + 3/2 NO		14 electric amplified	12 electric amplified	1,5÷9	14	16	P15F74424 P15F76624
3/2 NO + 3/2 NO		14 electric amplified	12 electric amplified	1,5÷9	14	16	P15F84424 P15F86624

o.c. = open centres    c.c. = closed centres    p.c. = pressurized centres

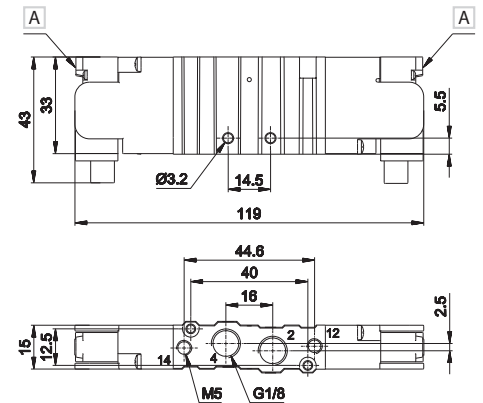

A Manual override

2 - 4 = Use  
14 = Control  
12 = Return

3

### Single electric impulse

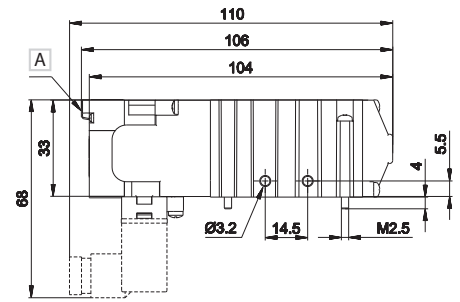
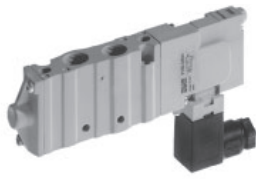

Weight (Kg): 0,142

	Symbol	Control	Return	Pressure bar	Resp. Time (ms)		Part no.
					En.	De-en.	
5/2		14	12	1,9÷9	15	24	P15D24024 P15D26024

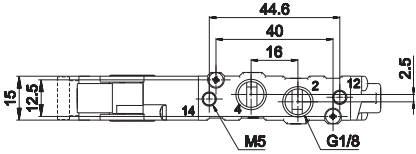

A Manual override

2 - 4 = Use  
14 = Control  
12 = Return

5/2		14	12	2÷9	12	21	P15D24124 P15D26124
-----	--	----	----	-----	----	----	------------------------

### Double electric impulse

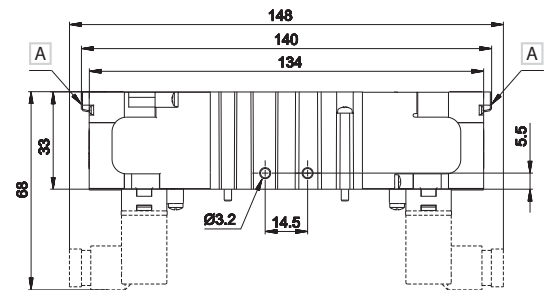
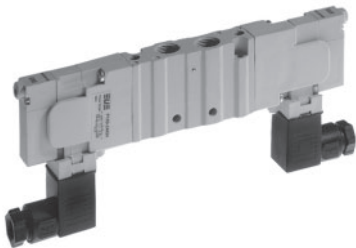

Weight (Kg): 0,166

> AM-5109 connector not included

	Symbol	Control	Return	Pressure bar	Resp. Time (ms)		Part no.
					En.	De-en.	
5/2		14	12	0,7÷9	16	16	P15D24424 P15D26624

A Manual override

2 - 4 = Use  
14 = Control  
12 = Return

5/3 c.c.		14	12	1,6÷9	11	35	P15D34424 P15D36624
----------	--	----	----	-------	----	----	------------------------

5/3 o.c.		14	12	1,6÷9	11	35	P15D44424 P15D46624
----------	--	----	----	-------	----	----	------------------------

5/3 p.c.		14	12	1,6÷9	11	35	P15D54424 P15D56624
----------	--	----	----	-------	----	----	------------------------

3/2 NC + 3/2 NC		14	12	1,5÷9	14	16	P15D64424 P15D66624
-----------------------	--	----	----	-------	----	----	------------------------

3/2 NC + 3/2 NO		14	12	1,5÷9	14	16	P15D74424 P15D76624
-----------------------	--	----	----	-------	----	----	------------------------

3/2 NO + 3/2 NO		14	12	1,5÷9	14	16	P15D84424 P15D86624
-----------------------	--	----	----	-------	----	----	------------------------

o.c. = open centres    c.c. = closed centres    p.c. = pressurized centres

### Single pneumatic impulse



Weight (Kg): 0,042

	Symbol	Control	Return	Pressure bar	Resp. Time (ms)		Part no.
					En.	De-en.	
5/2		pneumatic amplified	pneumo mechanical spring	1,9÷10	11	15	P15F230
5/2		pneumatic amplified	mechanical spring	2÷10	10	14	P15F231

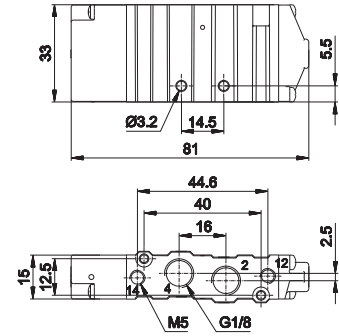

2 - 4 = Use  
14 = Control  
12 = Return

### Double pneumatic impulse



Weight (Kg): 0,044

	Symbol	Control	Return	Pressure bar	Resp. Time (ms)		Part no.
					En.	De-en.	
5/2		pneumatic amplified	pneumatic amplified	0,7÷10	10	10	P15F233
5/3 c.c.		pneumatic amplified	pneumatic amplified	1,6÷10	9	21	P15F333
5/3 o.c.		pneumatic amplified	pneumatic amplified	1,6÷10	9	21	P15F433
5/3 p.c.		pneumatic amplified	pneumatic amplified	1,6÷10	9	21	P15F533
3/2 NC + 3/2 NC		pneumatic amplified	pneumatic amplified	1,3÷10	10	14	P15F633
3/2 NC + 3/2 NO		pneumatic amplified	pneumatic amplified	1,3÷10	10	14	P15F733
3/2 NO + 3/2 NO		pneumatic amplified	pneumatic amplified	1,3÷10	10	14	P15F833

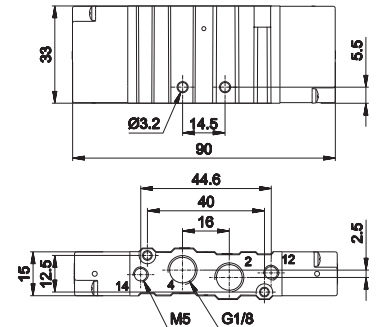

2 - 4 = Use  
14 = Control  
12 = Return

o.c. = open centres    c.c. = closed centres    p.c. = pressurized centres

3

Integrated electric connection

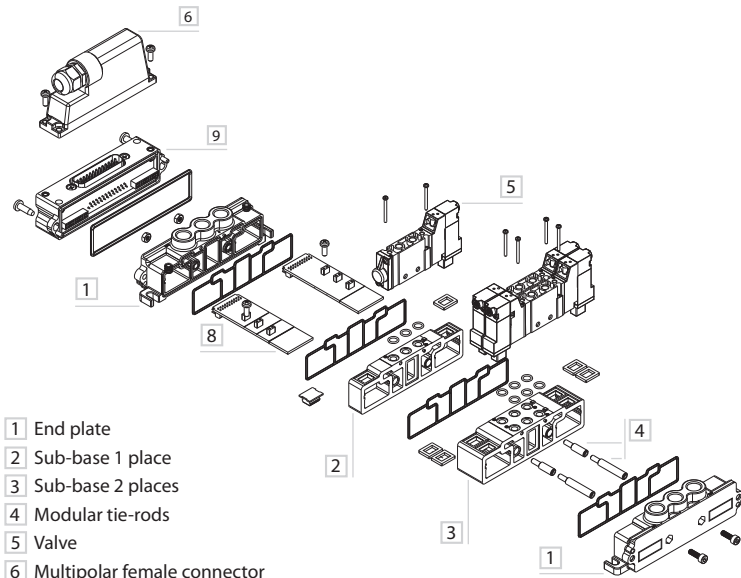
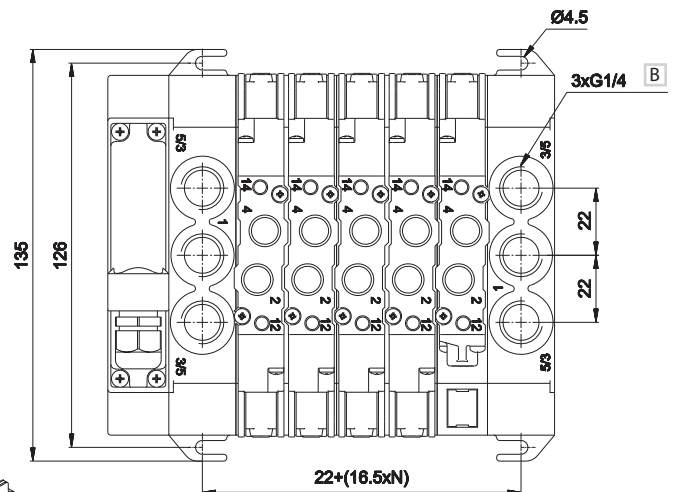
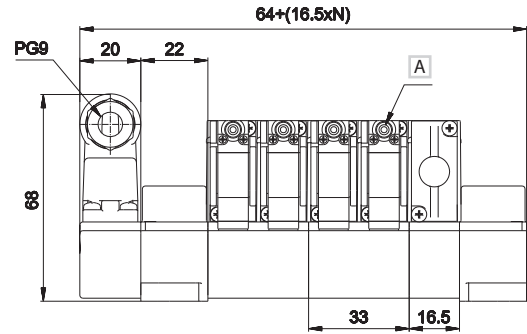
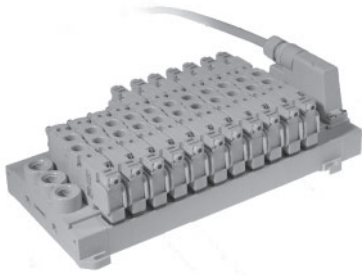

- 1 End plate
- 2 Sub-base 1 place
- 3 Sub-base 2 places
- 4 Modular tie-rods
- 5 Valve
- 6 Multipolar female connector
- 7 Single connector
- 8 Bus connection card
- 9 Multipole connection module

- 1 = Supply port
- 2 - 4 = Use
- 3 - 5 = Exhaust
- 14 = Control
- 12 = Return
- A Manual override
- B Tightening torque G1/4 = max 10 Nm

N = Number of valve places

TIM1524	TIM151806	TIM1536	P15SF100	P15SF110	P15SF200	P15SF210
---------	-----------	---------	----------	----------	----------	----------

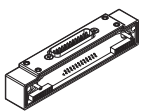

connection module  
25 poles male  
12+12 coils  
type D-sub  
weight: 0,047 Kg

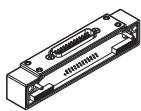

connection module  
25 poles male  
18 coils, side 14  
6 coils, side 12  
type D-sub  
weight: 0,055 Kg

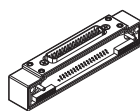

connection module  
37 poles male  
16+16 coils  
type D-sub  
weight: 0,057 Kg

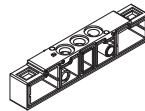

sub-base 1 place  
weight: 0,037 Kg

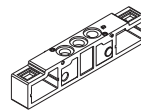

sub-base 1 place  
1-3-5 closed  
weight: 0,038 Kg

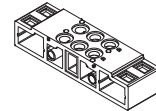

sub-base 2 places  
weight: 0,073 Kg

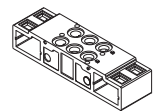

sub-base 2 places  
1-3-5 closed  
weight: 0,074 Kg

P15SF500	P15SF505	P15SF550	P15SF560	P15SF570	P15SS**01MC	P15SS**..M
----------	----------	----------	----------	----------	-------------	------------

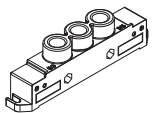

supply plate G1/4 left  
for TIM module  
weight: 0,064 Kg

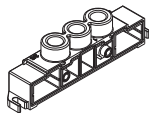

supply plate G1/4 right  
weight: 0,065 Kg



supply pressure  
separator plate  
weight: 0,003 Kg

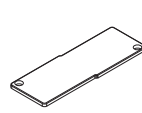

covering plate for  
unused valve place  
weight: 0,007 Kg

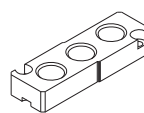

intermediate supply plate  
for threaded version  
weight: 0,011 Kg

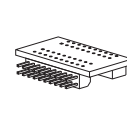

U-bus connection  
card, male  
\*\* = side 14 or 12  
weight: 0,004 Kg

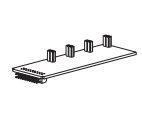

bus connection  
card, male  
\*\* = side 14 or 12  
.. = 04, 06, 08 places  
weight: 0,009 Kg 04 places  
0,010 Kg 06 places  
0,013 Kg 08 places

P15SS**08MF	P15SS**04MFP	P15SS**04MP	P15STR01	P15STR02	P15STR05
-------------	--------------	-------------	----------	----------	----------

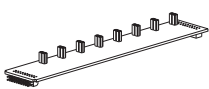

bus connection card  
male/female  
\*\* = side 14 or 12  
weight: 0,014 Kg

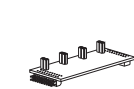

bus connection card  
male/female  
extension  
\*\* = side 14 or 12  
weight: 0,008 Kg

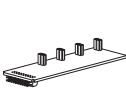

bus card  
extension  
\*\* = side 14 or 12  
weight: 0,006 Kg



modular tie-rods  
1 valve place  
(package 100 pcs.)  
weight: 0,003 Kg



modular tie-rods  
2 valve places  
(package 100 pcs.)  
weight: 0,007 Kg

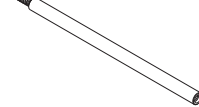

modular tie-rods  
5 valve places  
(package 100 pcs.)  
weight: 0,018 Kg

**AZ4-SN004A**  
100 nuts M4 for tie-rods

**AZ4-VN0414**  
100 screws 4x14 for tie-rods

Electric connection with external connector

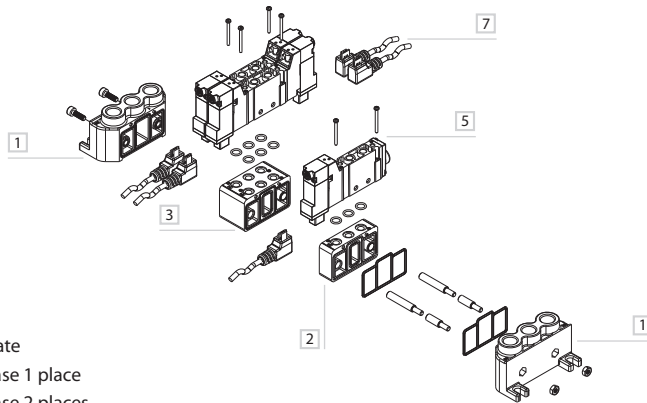
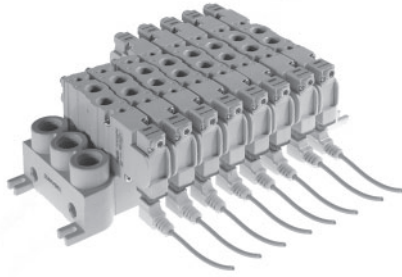

- 1 End plate
- 2 Sub-base 1 place
- 3 Sub-base 2 places
- 4 Modular tie-rods
- 5 Valve
- 6 Multipolar female connector
- 7 Single connector
- 8 Bus connection card
- 9 Multipole connection module

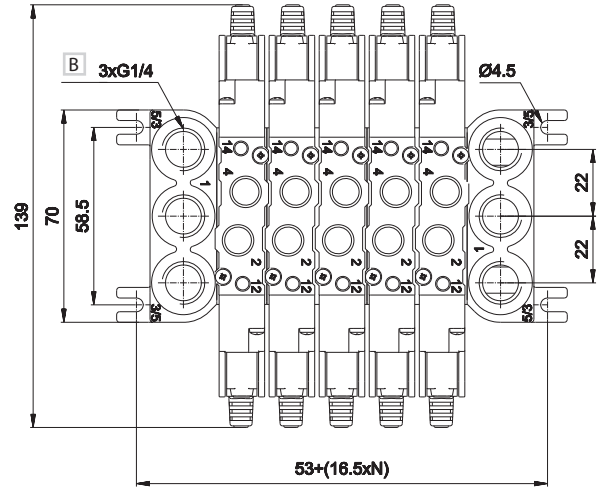
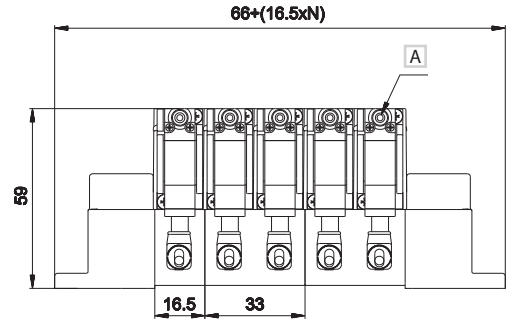

- 1 = Supply port
- 2 - 4 = Use
- 3 - 5 = Exhaust
- 14 = Control
- 12 = Return
- N = Number of valve places
- A Manual override
- B Tightening torque  
G1/4 = max 10 Nm

P15SF300	P15SF310	P15SF400	P15SF410	P15SF515	P15SF550	P15SF560
sub-base 1 place weight: 0,023 Kg	sub-base 1 place 1-3-5 closed weight: 0,024 Kg	sub-base 2 places weight: 0,046 Kg	sub-base 2 places 1-3-5 closed weight: 0,048 Kg	supply plate right/left G1/4 weight: 0,050 Kg	supply pressure separator plate weight: 0,001 Kg	covering plate for unused valve place weight: 0,007 Kg

P15SF570	P15STR01	P15STR02	P15STR05
intermediate supply plate for threaded version weight: 0,009 Kg	modular tie-rods 1 valve place (package 100 pcs.) weight: 0,003 Kg	modular tie-rods 2 valve places (package 100 pcs.) weight: 0,007 Kg	modular tie-rods 5 valve places (package 100 pcs.) weight: 0,018 Kg

**AZ4-SN004A**  
100 nuts M4 for tie-rods

**AZ4-VN0414**  
100 screws 4x14 for tie-rods

### Single electric impulse

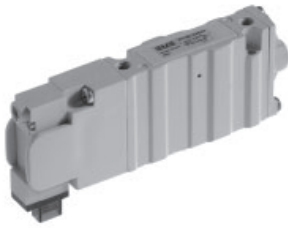

Weight (Kg): 0,138

	Symbol	Control	Return	Pressure bar	Resp. Time (ms)		Part no.
					En.	De-en.	
5/2		14	12	1,9÷9	15	24	P15B24024 P15B26024
5/2		14		2÷9	12	21	P15B24124 P15B26124

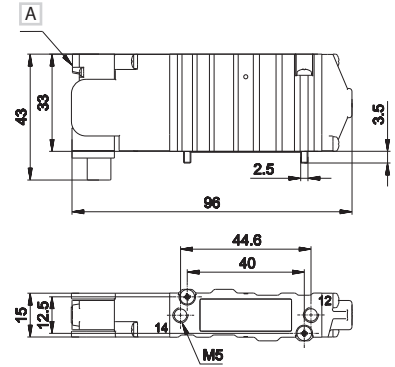

A Manual override

14 = Control  
12 = Return

### Double electric impulse

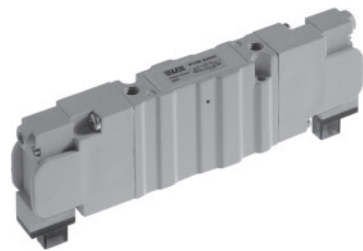

Weight (Kg): 0,158

	Symbol	Control	Return	Pressure bar	Resp. Time (ms)		Part no.
					En.	De-en.	
5/2		14	12	0,7÷9	11	11	P15B24424 P15B26624
5/3 c.c.		14	12	1,6÷9	11	35	P15B34424 P15B36624
5/3 o.c.		14	12	1,6÷9	11	35	P15B44424 P15B46624
5/3 p.c.		14	12	1,6÷9	11	35	P15B54424 P15B56624
3/2 NC + 3/2 NC		14	12	1,5÷9	14	16	P15B64424 P15B66624
3/2 NC + 3/2 NO		14	12	1,5÷9	14	16	P15B74424 P15B76624
3/2 NO + 3/2 NO		14	12	1,5÷9	14	16	P15B84424 P15B86624

o.c. = open centres    c.c. = closed centres    p.c. = pressurized centres

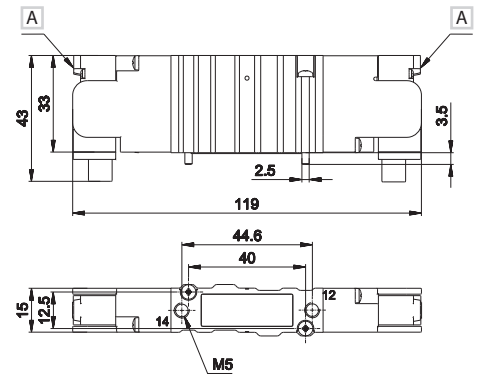

A Manual override

14 = Control  
12 = Return

### Single pneumatic impulse

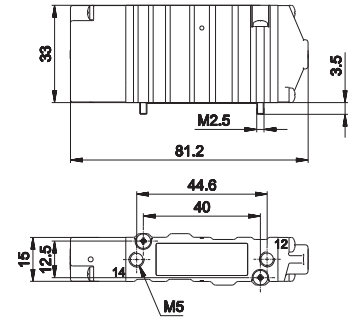

Weight (Kg): 0,127

	Symbol	Control	Return	Pressure bar	Resp. Time (ms)		Part no.
					En.	De-en.	
5/2		pneumatic amplified	pneumo mechanical spring	1,9÷9	11	15	P15B230
5/2		pneumatic amplified	mechanical spring	2÷9	10	14	P15B231

14 = Control  
12 = Return

### Double pneumatic impulse

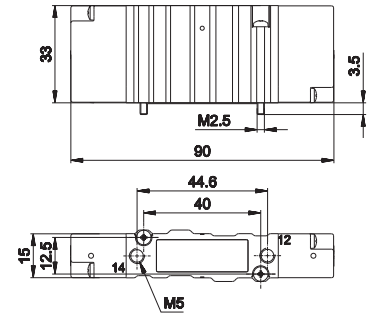

Weight (Kg): 0,132

	Symbol	Control	Return	Pressure bar	Resp. Time (ms)		Part no.
					En.	De-en.	
5/2		pneumatic amplified	pneumatic amplified	0,7÷9	10	10	P15B233
5/3 c.c.		pneumatic amplified	pneumatic amplified	1,6÷9	9	21	P15B333
5/3 o.c.		pneumatic amplified	pneumatic amplified	1,6÷9	9	21	P15B433
5/3 p.c.		pneumatic amplified	pneumatic amplified	1,6÷9	9	21	P15B533
3/2 NC + 3/2 NC		pneumatic amplified	pneumatic amplified	1,3÷9	10	14	P15B633
3/2 NC + 3/2 NO		pneumatic amplified	pneumatic amplified	1,3÷9	10	14	P15B733
3/2 NO + 3/2 NO		pneumatic amplified	pneumatic amplified	1,3÷9	10	14	P15B833

14 = Control  
12 = Return

o.c. = open centres    c.c. = closed centres    p.c. = pressurized centres

3



Integrated electric connection

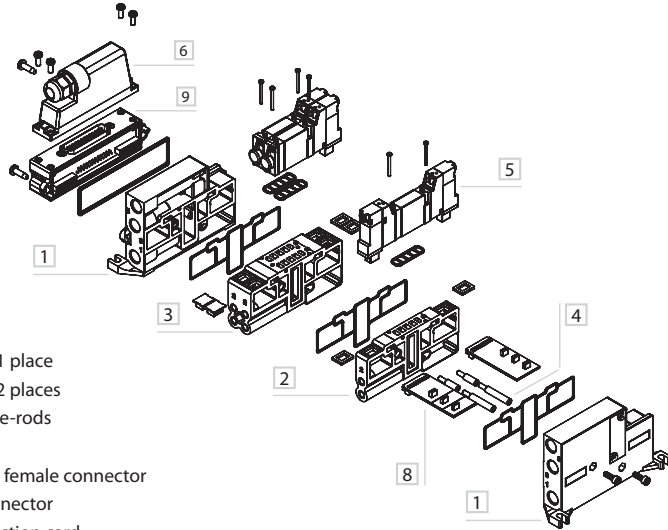
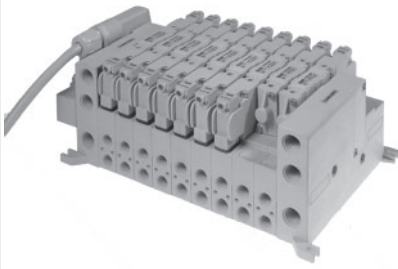

- 1 End plate
- 2 Sub-base 1 place
- 3 Sub-base 2 places
- 4 Modular tie-rods
- 5 Valve
- 6 Multipolar female connector
- 7 Single connector
- 8 Bus connection card
- 9 Multipole connection module

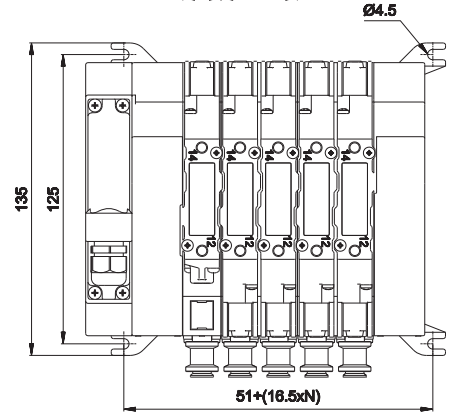
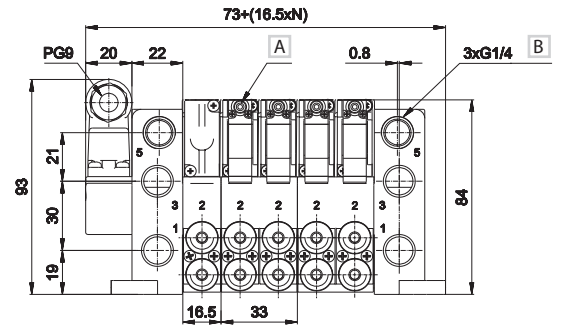

- 1 = Supply port
- 2 - 4 = Use
- 3 - 5 = Exhaust
- 14 = Control
- 12 = Return
- A Manual override
- B Tightening torque
- G1/4 = max 10 Nm
- G1/8 = max 3 Nm

N = Number of valve places

TIM1524	TIM151806	TIM1536	P15SB100	P15SB110	P15SB200	P15SB210
connection module 25 poles male 12+12 coils type D-sub weight: 0,047 Kg	connection module 25 poles male 18 coils side 14 6 coils side 12 type D-sub weight: 0,055 Kg	connection module 37 poles male 16+16 coils type D-sub weight: 0,057 Kg	sub-base 1 place side outlets G1/8 integrated version weight: 0,060 Kg	sub-base 1 place side outlets G1/8 integrated version 1-3-5 closed weight: 0,060 Kg	sub-base 2 places side outlets G1/8 weight: 0,133 Kg	sub-base 2 places side outlets G1/8 integrated version 1-3-5 closed weight: 0,133 Kg
P15SB300	P15SB310	P15SB400	P15SB410	P15SB500	P15SB505	P15SB550
sub-base 1 place side outlets for quick couplings integrated version weight: 0,060 Kg	sub-base 1 place side outlets for quick couplings 1-3-5 closed weight: 0,060 Kg	sub-base 2 places side outlets for quick couplings integrated version weight: 0,133 Kg	sub-base 2 places side outlets for quick couplings 1-3-5 closed weight: 0,133 Kg	supply plate G1/4 left for TIM module weight: 0,127 Kg	supply plate G1/4 right weight: 0,124 Kg	supply pressure separator plate weight: 0,003 Kg
P15SB560	P15SB570	P15SS**01MC	P15SS**..M	P15SS**08MF	P15SS**04MFP	P15SS**04MP
covering plate for unused valve place weight: 0,007 Kg	intermediate supply plate for sub-base weight: 0,016 Kg	U-bus connection card, male ** = lato14 o 12 weight: 0,004 Kg	bus connection card male ** = side14 or 12 .. = 04, 06, 08 places weight: 0,009 Kg 04 places 0,010 Kg 06 places 0,013 Kg 08 places	bus connection card male/female extension ** = side14 or 12 weight: 0,014 Kg	bus connection card male/female extension ** = side14 or 12 weight: 0,008 Kg	bus card extension ** = side14 or 12 weight: 0,006 Kg

P15STR01	P15STR02	P15STR05	GZR-V100..
modular tie-rods 1 valve place (package 100 pcs.) weight: 0,003 Kg	modular tie-rods 2 valve places (package 100 pcs.) weight: 0,007 Kg	modular tie-rods 5 valve places (package 100 pcs.) weight: 0,018 Kg	fitting .. = 04, 06, 08 places weight: 0,013 Kg

AZ4-SN004A

100 nuts M4 for tie-rods

AZ4-VN0414

100 screws 4x14 for tie-rods

D-535U40300  
D-535U40500

AM-5109

TSCFN24S000  
TSCFN36S000

TSCFN24S0300  
TSCFN24S0500  
TSCFN24S1000  
TSCFN32S0300  
TSCFN32S0500  
TSCFN32S1000

TSCFN16D0300  
TSCFN16D0500  
TSCFN16D1000

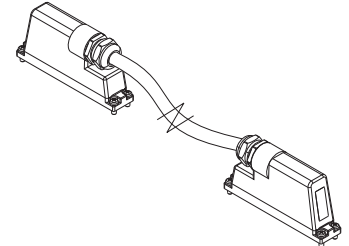
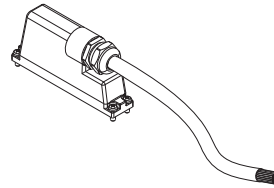
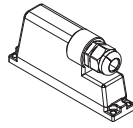
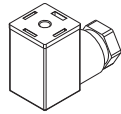
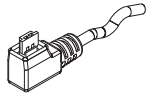

■ single connector with cable 3-5 m

■ 15 mm connector

■ female connector 25/37 poles type D-sub no cable  
M3 x 8 fixing screws

■ female connector 25/37 poles type D-sub with cable 3-5-10 m  
M3 x 8 fixing screws

■ flying male/female connector sub D (upon request) prewired for 24 coils with cable Ø 8 mm (3-5-10 m length) suitable for mobile laying  
M3 x 8 fixing screws

Colour identification according to standard DIN 47100

Female D-SUB 25 poles for connection 12+12 coils

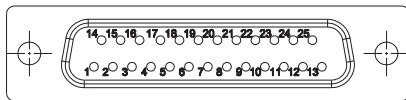

Female D-SUB 37 poles for connection 16+16 coils

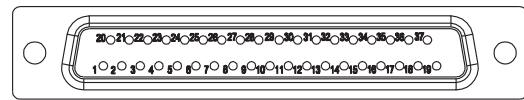

PIN No.	Colour	Coil	Control side		Valve No.
			TIM1524	TIM151806	
1	white	1	14	14	1
2	brown	2	12	12	1
3	green	3	14	14	2
4	yellow	4	12	12	2
5	grey	5	14	14	3
6	pink	6	12	12	3
7	blue	7	14	14	4
8	red	8	12	12	4
9	black	9	14	14	5
10	violet	10	12	12	5
11	grey-pink	11	14	14	6
12	red-blue	12	12	12	6
13	white-green	13	14	14	7
14	brown-green	14	12	14	7
15	white-yellow	15	14	14	8
16	yellow-brown	16	12	14	8
17	white-grey	17	14	14	9
18	grey-brown	18	12	14	9
19	white-pink	19	14	14	10
20	pink-brown	20	12	14	10
21	white-blue	21	14	14	11
22	brown-blue	22	12	14	11
23	white-red	23	14	14	12
24	brown-red	common	-	-	-
25	white-black	24	12	14	12

PIN No.	Colour	Coil	Control side		Valve No.
			TIM1524	TIM151806	
1	white	1	14	14	1
2	brown	2	12	12	1
3	green	3	14	14	2
4	yellow	4	12	12	2
5	grey	5	14	14	3
6	pink	6	12	12	3
7	blue	7	14	14	4
8	red	8	12	12	4
9	black	9	14	14	5
10	violet	10	12	12	5
11	grey-pink	11	14	14	6
12	red-blue	12	12	12	6
13	white-green	13	14	14	7
14	brown-green	14	12	14	7
15	white-yellow	15	14	14	8
16	yellow-brown	16	12	14	8
17	white-grey	17	14	14	9
18	grey-brown	18	12	14	9
19	white-pink	19	14	14	10
20	pink-brown	20	12	14	10
21	white-blue	21	14	14	11
22	brown-blue	22	12	14	11
23	white-red	23	14	14	12
24	brown-red	24	12	14	12
25	white-black	25	14	14	12
26	brown-black	26	12	14	13
27	grey-green	27	14	14	14
28	yellow-grey	28	12	14	14
29	pink-green	29	14	14	15
30	yellow-pink	30	12	14	15
31	green-blue	31	14	14	16
32	yellow-blue	32	12	14	16
33	-	not used	-	-	-
34	-	not used	-	-	-
35	-	not used	-	-	-
36	yellow-black	common	-	-	-
37	yellow-red shield	common law	-	-	-

3