

Articulated attachment for vacuum pad Free holder

- Suitable for picking up work-pieces with non-vertical position or with unfixed angle.

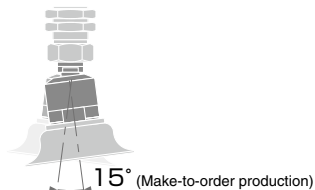
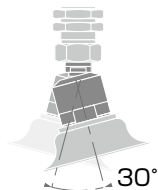

Free Holder

Model Designation (Example)

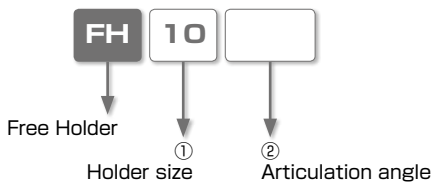

①. Holder size

Code	10	20	60
Pad size (mm)	ø10, ø15	ø20 ~ ø50, 4×10 ~ 8×30	ø60 ~ ø100

※ . Holder size code "20" is applicable for pad size ø10mm and ø15mm for sponge series due to the structural reasons.

②. Articulation angle

Code	No code	-15
Articulation angle	30°	15° (option)

How to install

1. Fixing Method

- ①. Use a proper tool to tighten the knurling part of FH10 and FH20 or use a spanner to tighten the parallel cut part of FH60. Refer to the dimensional drawings of the parallel cut part.

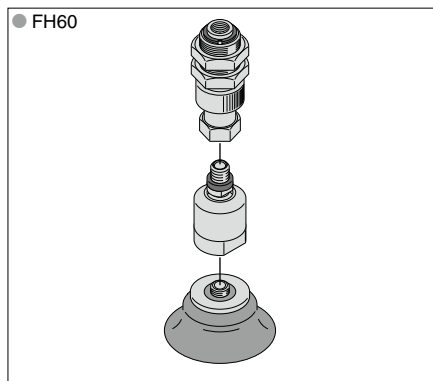
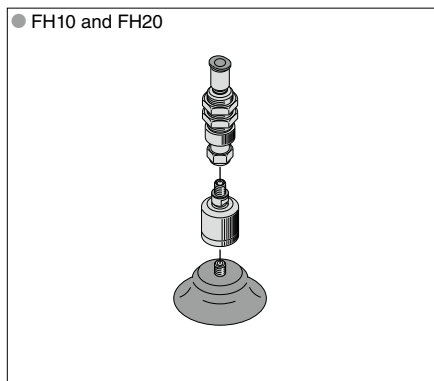

⚠ Detailed Safety Instructions

Before using PISCO products, be sure to read "Safety Instructions" and "Common Safety Instructions for Products Listed in This Catalog on page 43-49, and "Common Safety Instructions for Vacuum Series" on page 55-56.

Warning

1. Free holder shall not be combined with non-PISCO brand vacuum pad and pad direct mounting filter. Do not use it for other purpose. Free holder is designed for PISCO vacuum pad only. Thus wrong usage may cause damage to the product.
2. When a work-piece is conveyed a pad with Free Holder, consider the acceleration, impacts and wind pressure. Otherwise, the work-piece may drop from the vacuum pad during transportation and there is a possibility of damaging the holder.
3. Avoid any excessive pressure on Free holder. Otherwise, there is a possibility of damaging the holder.

Caution

1. Pay special attention to the angle position of Free holder. The angle position can be changed after sucking work-piece by work-piece weight and acceleration or impact during transportation.
2. When Free holder is attached or replaced, refer to the following tightening torque to tighten the parallel cut part of the holder.

● Table : Tightening torque

Thread size (mm)	Tightening torque
M4x0.7	0.6 ~ 0.7N·m
M6x1	1.5 ~ 2N·m
M10x1.5	5 ~ 8N·m

■ Related Products

Vacuum Pad Series

- Vacuum Pad Standard Series ··· P.490
- Vacuum Pad Sponge Series ··· P.536
- Vacuum Pad Bellows Series ··· P.560
- Vacuum Pad Oval Series ··· P.622
- Vacuum Pad Soft Series ··· P.654
- Vacuum Pad Soft Bellows Series · P.694
- Vacuum Pad Skidproof Series ··· P.730
- Vacuum Pad Flat Series ··· P.774
- Vacuum Pad Long Stroke Series · P.818

Free Holder



FH Free Holder

RoHS compliant

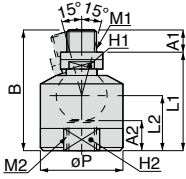

Unit : mm

Model code	M1	M2	A1	A2	B	L1	L2	øP	Hex. H1	Hex. H2	Weight (g)	CAD file name
FH10□	M4x0.7	M4x0.7	3.4	7	23	19.6	11.1	15	4	—	9	VVP-229
FH20□	M6x1	M6x1	6	6.5	28.5	22.5	12.5	20	7	—	20	
FH60□	M10x1.5	M10x1.5	10	9.5	40.5	30.5	18.5	28	12	24	58	

※ □ : Replaced with "-15" for articulation angle : 15 degrees. (Make-to-order production)

Construction (FH10)

● Pad dia. : ø10mm, ø15mm

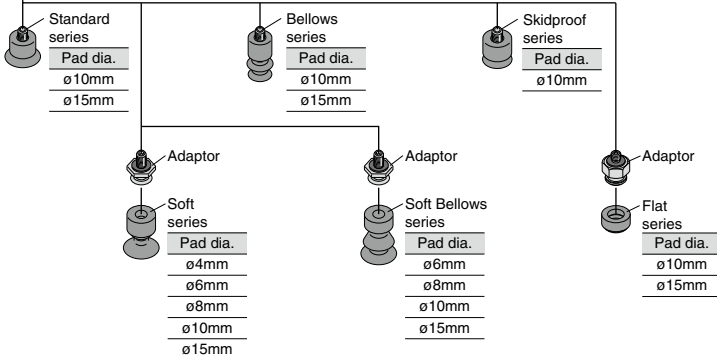
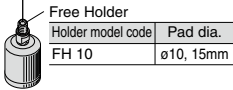
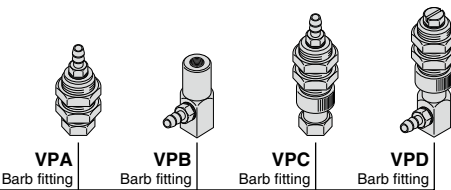
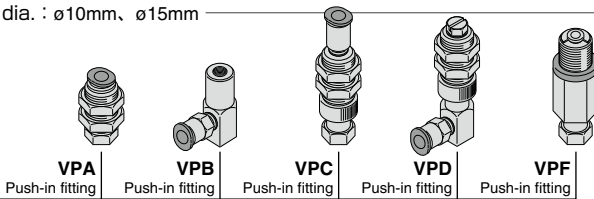

Construction (FH20)

- Pad dia. : $\phi 10\text{mm}$, $\phi 15\text{mm}$, $\phi 20\text{mm}$, $\phi 25\text{mm}$, $\phi 30\text{mm}$, $\phi 35\text{mm}$, $\phi 40\text{mm}$, $\phi 50\text{mm}$,
 $2 \times 4\text{mm}$, $3.5 \times 7\text{mm}$, $4 \times 10\text{mm}$, $4 \times 20\text{mm}$, $4 \times 30\text{mm}$, $5 \times 10\text{mm}$, $5 \times 20\text{mm}$, $5 \times 30\text{mm}$,
 $6 \times 10\text{mm}$, $6 \times 20\text{mm}$, $6 \times 30\text{mm}$, $8 \times 20\text{mm}$, $8 \times 30\text{mm}$

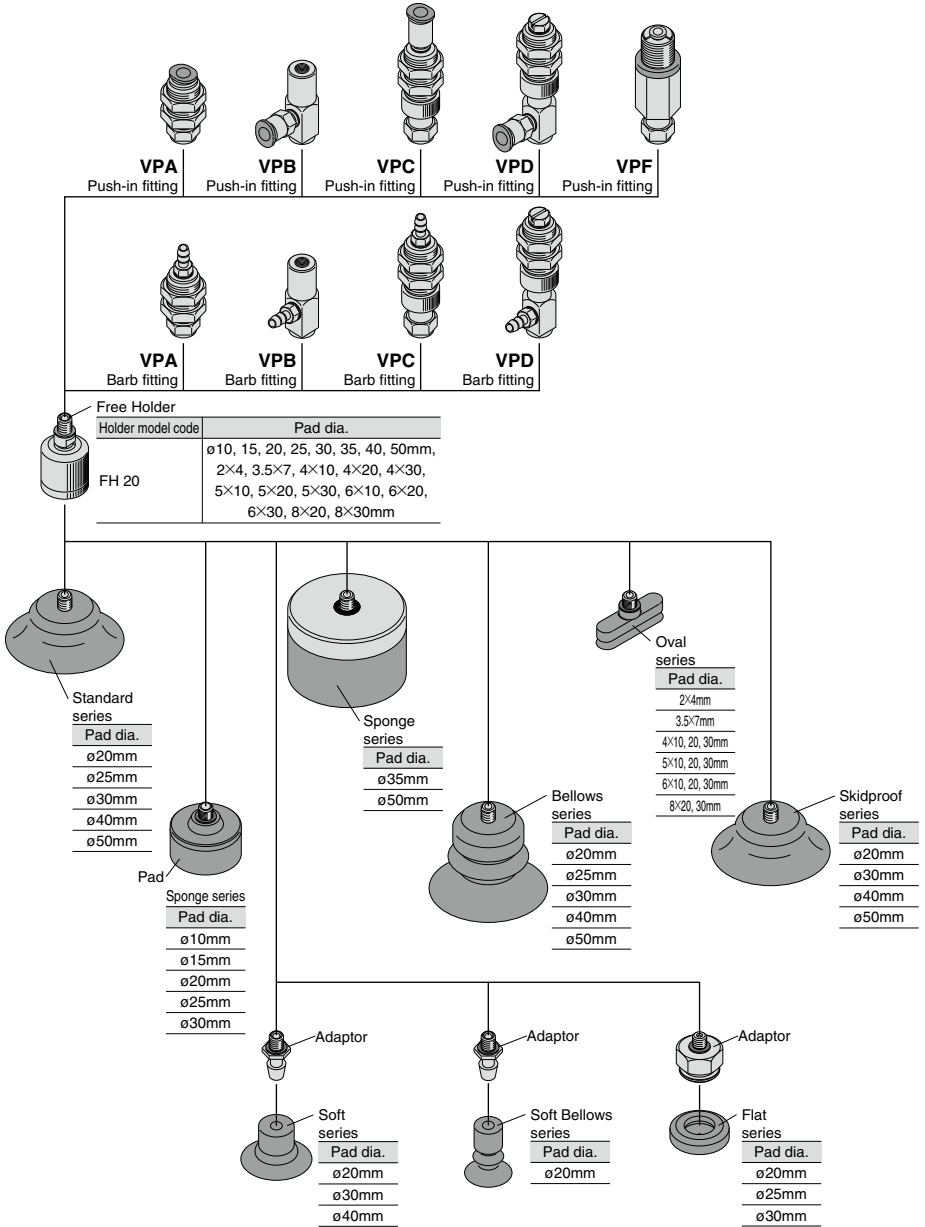

Free Holder

Construction (FH60)

● Pad dia. : $\phi 60\text{mm}$, $\phi 70\text{mm}$, $\phi 80\text{mm}$, $\phi 100\text{mm}$

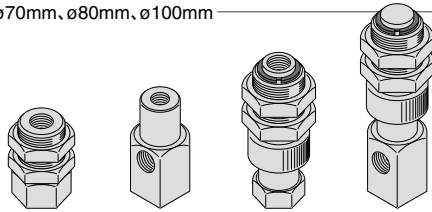

VPA Parallel female thread | **VPB** Parallel female thread | **VPC** Parallel female thread | **VPD** Parallel female thread

Free Holder

Holder model code	Pad dia.
FH 60	$\phi 60, 70, 80, 100\text{mm}$

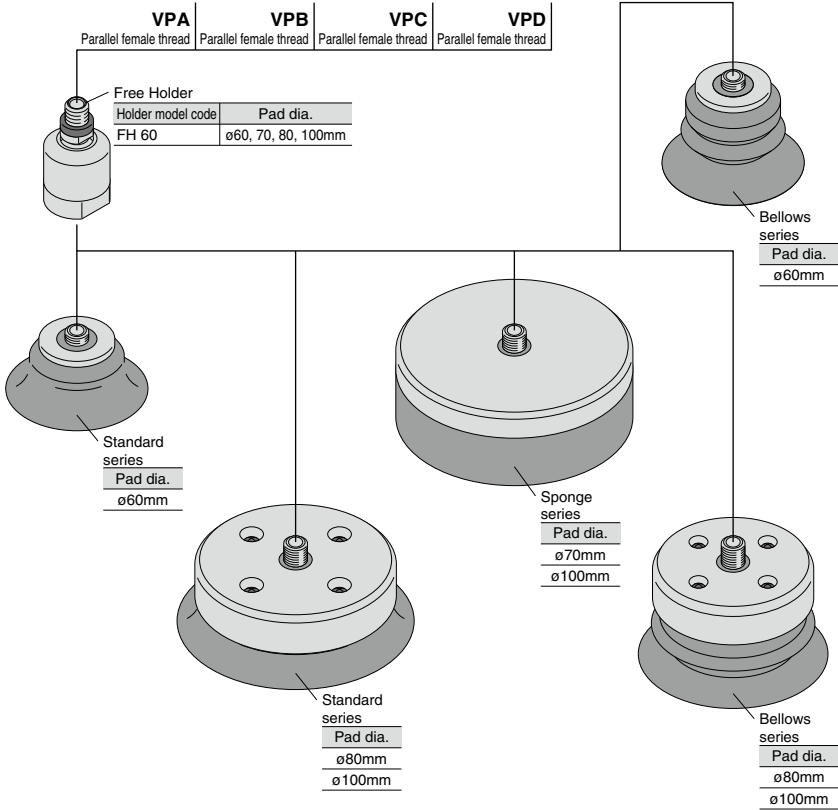

Standard series
Pad dia.
 $\phi 60\text{mm}$

Bellows series
Pad dia.
 $\phi 60\text{mm}$

Sponge series
Pad dia.
 $\phi 70\text{mm}$
 $\phi 100\text{mm}$

Standard series
Pad dia.
 $\phi 80\text{mm}$
 $\phi 100\text{mm}$

Bellows series
Pad dia.
 $\phi 80\text{mm}$
 $\phi 100\text{mm}$

Common Safety Instructions for Vacuum Series

Before selecting or using PISCO products, read the following instructions. Read the detailed instructions for individual series.

Warning

1. If there is a risk of dropping work-pieces during vacuum suction, take a safety measure against the falling of them.
2. Avoid supplying more than 0.1MPa pressure constantly in a vacuum circuit. Since vacuum generators are not explosive-proof, there is a risk of damaging the products.
3. Pay attention to drop of vacuum pressure caused by problems of the supplied air or the power supply. Decrease of suction force may lead to a danger of falling work-piece so that safety measure against the falling of them is necessary.
4. When more than 2 vacuum pads are plumbed on a single ejector and one of them has a suction problem such as vacuum leak, there is a risk of releasing work-pieces from the other pad due to the drop of the vacuum pressure.
5. Do not use in the way by which exhaust port is blocked or exhaust resistance is increased. Otherwise, there is a risk of no vacuum generation or a drop of the vacuum pressure.

Caution

1. Carry out clogging check for silencer element in an ejector and a vacuum filter periodically. Clogged element will be a cause to impair the performance or a cause of troubles.
2. Before replacing the element, thoroughly read and understand the method of filter replacement in the user's manual enclosed in the product package.
3. Keep the product away from water, oil drops or dusts. These may cause malfunction. Take a proper measure to protect the product before the operation.
4. Refer to "9. Installation of a fitting" under "Common Safety Instructions for Products Listed in This Catalog", when installing or removing fittings.
5. Refer to "Common Safety Instructions for Sensors" and "Detailed Safety Instructions" of each series for the handling of digital pressure sensors.
6. Refer to "Common Safety Instructions for Mechanical Pressure Sensors" for the handling of mechanical pressure sensor.
7. The material of plastic filter cover for VG, VK, VJ, VZ, VX, VJP, VZP, VXP/VXPT, VFU2 and VFU3 series is PCTG. Avoid the adherence of chemicals below to the products, and do not use them under those chemical environments.

● Table. Chemical Name

Chemical Name	Chemical Name	Chemical Name
Acetone	Silicone oil	Methyl alcohol (Methanol)
Aniline	Ammonium hydroxide	Lacquer
Hydrogen chloride gas	Ammonium hydroxide concentrated	Sulfuric acid (10% 20°C)
Chloroform	Trichloroethylene (Trichlene)	Sulfuric acid concentrated (20°C)
Ethyl acetate	Toluene	Sulfuric acid concentrated (70°C)
Carbon tetrachloride	Ethylene dichloride	
Cyclohexane	Lactic acid (high temperature)	
Dimethylformamide (DMF)	Lactic acid (low temperature)	
Nitric acid (61% 20°C) (concentrated nitric acid solution)	Phenol	
Silicone grease	Benzene (Benzol)	

* There are more chemicals which should be avoided. Contact us for the use under chemical circumstance.

8. The material of plastic filter cover for VQ, VQP, VFUO and VFU1 series is PA. Avoid the adherence of chemicals below to the products, and do not use them under those chemical environments.

● Table. Chemical Name

Chemical Name	Chemical Name	Chemical Name
Aniline	Chromic acid (10% 70°C)	Water vapor (260°C or higher)
Ethylene chlorohydrin	Chromic acid (25% 70°C)	Tetrachloroethane
Epichlorohydrin	Chlorosulfonic acid	Tetrahydrofuran
Chloroethyl (Chloroethane)	Chlorotoluene	Trichloroethylene (Trichlene)
Thionyl chloride	Chlorobenzene	Ethylene dichloride
Benzyl chloride	Chloroform	Methylene dichloride
Methyl chloride	Acetic acid (Acetic anhydride)	Nitrobenzene
Hydrochloric acid (20% 80°C)	Hypochlorous acid	Carbon disulfide
Hydrochloric acid (37% 20°C)	Calcium hypochlorite	Perchloroethylene
Aqua regia	Sodium hypochlorite (5% 70°C)	Phenol
Ozone	Ethane tetrachloride	Benzyl chloride
Sodium peroxide	Carbon tetrachloride	Acetic anhydride
Caustic soda (30% 70°C)	Dichlorobenzene	Mono-chlorobenzene (Chlorobenzene)
Potassium permanganate	Dimethylformamide (DMF)	Mono-chloroethanoic acid (Chloroethanoic acid)
Formic acid (50% 20°C)	Hydrobromic Acid (20% 20°C)	Sulfuric acid concentrated (20°C)
Formic acid (90% 20°C)	Hydrobromic Acid (40% 20°C)	Sulfuric acid concentrated (Oleum)
Cresol	Bromine	Phosphoric acid concentrated
Chromic acid (2% 70°C)	Water vapor (204°C ~ 260°C)	
Chromic acid (2% 50°C)	Water vapor (204°C or lower)	

* There are more chemicals which should be avoided. Contact us for the use under chemical circumstance.

VACUUM
PAD
ACCESSORIES

VH-VS
VU
VUM
VY
VB
VM-VC
VRL
VVV
VG
VQ
VK
VJ
VX
VN
VZ

Safety Instructions

This Safety Instructions aim to prevent personal injury and damage to properties by requiring proper use of PISCO products.

Be certain to follow ISO 4414 and JIS B 8370.

ISO 4414 : Pneumatic fluid power...General rules and safety requirements for system and their components.

JIS B 8370 : General rules and safety requirements for systems and their components.

This Safety instructions are classified into "Danger", "Warning" and "Caution", depending on the degree of danger or damages caused by improper use of PISCO products.



Danger

Hazardous conditions. It can cause death or serious personal injury.



Warning

Hazardous conditions depending on usages. Improper Use of PISCO products can cause death or serious personal injury.



Caution

Hazardous conditions depending on usages. Improper use of PISCO products can cause personal injury or damages to properties.

Danger

1. Do not use PISCO products for the following applications.
 - ①. Equipment used for maintaining / handling human life and body.
 - ②. Equipment used for moving / transporting human.
 - ③. Equipment specifically used for safety purposes.

Warning

1. Selection of pneumatic products.
 - ① A user who is a pneumatic system designer or has sufficient experience and technical expertise should select PISCO products.
 - ② Due to wide variety of operating conditions and applications for PISCO products, carry out the analysis and evaluation on PISCO products. The pneumatic system designer is solely responsible for assuring that the user's requirements are met and that the application presents no health or safety hazards. All designers are required to fully understand the specifications of PISCO products and constitute all systems based on the latest catalog or information, considering any malfunction.
2. Usage environment

Do not use PISCO products under the following conditions.

 - ①. Beyond the specifications or conditions stated in the catalog, or the instructions.
 - ②. Use at outdoors.
 - ③. Excessive vibrations and impacts.
 - ④. Exposure / adhere to corrosive gas, flammable gas, chemicals, seawater, water and vapor.

3. Handling of product

- ①. The pneumatic equipments shall be handled by a person having enough knowledge and experiences. Improper use of compressed air is dangerous. Assembly, operation and maintenance of machines using pneumatic equipment should be conducted by a person with enough knowledge and experience.
- ②. Do not operate machine / equipment or remove pneumatic equipment until safety is confirmed.
 - (1). Make sure that preventive measures against falling work-pieces or sudden movements of machine are completed before inspection or maintenance of these machine.
 - (2). Make sure the above preventive measures are completed. A compressed air supply and the power supply to the machine must be off, and also the compressed air in the systems must be exhausted.
 - (3). Restart the machines with care after ensuring to take all preventive measures against sudden movements.
- ③. Do not disassemble or modify PISCO products, which affect the performance, function, and basic structure of the product.
- ④. Take safety measures such as providing a protection cover if there is a risk of causing damages or fire on machine / facilities by a fluid leakage.
- ⑤. Do not touch the release-ring of push-in fitting when there is a working pressure.
- ⑥. Frequent switchover of compressed air may generate heat, and there is a risk of causing burn injury.
- ⑦. Avoid any load on PISCO products, such as, a tensile strength, twisting and bending. Otherwise, there is a risk of causing damage to the products.
- ⑧. Do not use PISCO products for applications where threads or tubes swing / rotate. The product can be damaged in these applications.
- ⑨. Do not force the product to rotate or swing even its resin body is rotatable. It may cause damage to the product and a fluid leakage.
- ⑩. Do not supply excessively dry air to products. It may cause malfunction due to a deterioration of rubber parts.
- ⑪. Do not wash or paint products with water or solvent. Solvent may damage a resin body, or painting may cause malfunction.
- ⑫. The product incorporating NBR as seal rubber material has a risk of malfunction caused by ozone crack. Ozone exists in high concentrations in static elimination air, clean-room, and near the high-voltage motors, etc. As a countermeasure, material change from NBR to HNBR or FKM is necessary. Consult with PISCO for more information.
- ⑬. Do not stand on a product, or put anything on it. It may cause falls, personal injury or damage to the product.

Warranty

When the product produces a trouble, which is caused by our responsibility, we will carry out either one of the following measures immediately.

- ①. Free-of-charge replacement of same product
- ②. Free-of-charge repair of the product at our factory

Disclaimer

1. PISCO does not take any responsibility for any incidental or indirect loss, such as production line stop, interruption of business, loss of benefits, personal injury, etc., caused by any failure on use or application of PISCO products.
2. When a cause of the trouble/malfunction applies to any of the following items, it is excluded from the coverage of the above warranty.
 - ①. A case by a natural disaster, a fire except our responsibility, the act by the third person/party, the intention or fault of the customer.
 - ②. A case when a product is used out of the specific range or the method listed in the product catalog or the instruction manual.
 - ③. A case by the remodeling of the product or by a change of structure, performance, or specifications which PISCO does not involved in.
 - ④. A case by the event that is unpredictable by the evaluations and the measures at the time on or before the initial delivery.
 - ⑤. A case caused by the phenomenon that is able to be evaded if your machine or equipment has functions or structures that are comprised in a common sense when this product is incorporated in your machine or equipment.
3. The damages caused by the defect of PISCO products shall be covered but limited to the full amount of the PISCO products paid by the customer. Additionally, the above warranty is limited simply to the product itself. The damage induced by the trouble of the product will not be compensated.



Common Safety Instructions for Products Listed in This Catalog

⚠ Caution

1. An odd noise may be heard when supply pressures are immediately before the peak of vacuum levels. The sounding of this odd noise means the characteristics are unstable and the sound may become even noisier. This situation can also adversely affect the sensor, resulting in a malfunction or trouble. So reset the supply pressure.
 - ※. Pressure range in which odd noise occurs is affected by atmospheric pressure.
2. Piping design and equipment selection should be made with an effective sectional area on supply pressure side of a vacuum generator being 3 times as large as the nozzle diameter as a standard. Insufficient air flow may impair the performance of the product.
3. Do not use a lubricator on products.
4. Clean or replace silencer element periodically. There is a possibility of dropping the performance or causing troubles by clogging on the element.
5. Keep products away from water, oil drops or dusts because they are neither drip-proof nor dust-proof. Otherwise there is a possibility of causing malfunction, damage to the products, or dropping the performance.
6. Piping
 - ①. Compressed air contains a volume of drain (water, oxidized oil and foreign material, etc.) Because the drain reduce product performance remarkably, dehumidify air with an aftercooler and a dryer, and improve the air quality.
 - ②. Do not use a lubricator on products.
 - ③. Rust in pipe and inflow of foreign substances cause the trouble, malfunction, and degradation of the product. Please install a filter (5 μ m or better filtration) in the compressed air supply line right in front of the product. The flushing inside the pipe before use and in certain intervals is recommended.
 - ④. Remove dusts or drain before piping. They may get into the peripheral machine / facilities and cause malfunction.
 - ⑤. When inserting an ultra-soft tube into push-in fitting, make sure to place an Insert Ring into the tube edge. There is a risk of causing the escape of tube and a fluid leakage without using an Insert Ring.
 - ⑥. Arrange piping avoiding any load on fittings and tubes such as twist, tensile, moment load, shaking and physical impact. These may cause damages to fittings, tube deformations, bursting and the escape of tubes.
 - ⑦. Install protective cover when using at a place getting the direct sunlight.
 - ⑧. Be sure to confirm each port of a vacuum generator with its appearance drawing or the marking on it before piping. Incorrect piping has a risk of damaging the product.
 - ⑨. Plumb a pressure sensor and a vacuum generator with pressure sensor at the end of vacuum system as much as possible. A long distance between a pressure sensor and a vacuum system end may increase plumbing resistance which may lead to a high vacuum level at the sensor even when no suctioning and a malfunction of pressure sensor. Make sure to evaluate the products in an actual system.

- ⑩. A Shorter distance of plumbing with a wider bore is preferable at vacuum system side. A long plumbing with a small bore may result in slow response time at the time of releasing work-piece as well as in failure to secure adequate suction flow rate.
- ⑪. In case of using non-PISCO brand tubes, make sure the tolerance of the outer tube diameter is within the limits of Table 1.

● Table 1. Tube O.D. Tolerance

mm size	Nylon tube	Polyurethane tube	inch size	Nylon tube	Polyurethane tube
ø1.8mm	—	±0.05mm	ø1/8	±0.1mm	±0.15mm
ø2mm	—	±0.05mm	ø5/32	±0.1mm	±0.15mm
ø3mm	—	±0.15mm	ø3/16	±0.1mm	±0.15mm
ø4mm	±0.1mm	±0.15mm	ø1/4	±0.1mm	±0.15mm
ø6mm	±0.1mm	±0.15mm	ø5/16	±0.1mm	±0.15mm
ø8mm	±0.1mm	±0.15mm	ø3/8	±0.1mm	±0.15mm
ø10mm	±0.1mm	±0.15mm	ø1/2	±0.1mm	±0.15mm
ø12mm	±0.1mm	±0.15mm	ø5/8	±0.1mm	±0.15mm
ø16mm	±0.1mm	±0.15mm			

7-1. Tube insertion (Push-in fitting)

- ①. Make sure that the cut end surface of the tube is at a right angle without a scratch on the tube surface or deformations.
- ②. When inserting a tube, the tube needs to be inserted fully into the push-in fitting until the tubing edge touches the tube end of the fitting as shown in the figure below. Otherwise, there is a risk of leakage.

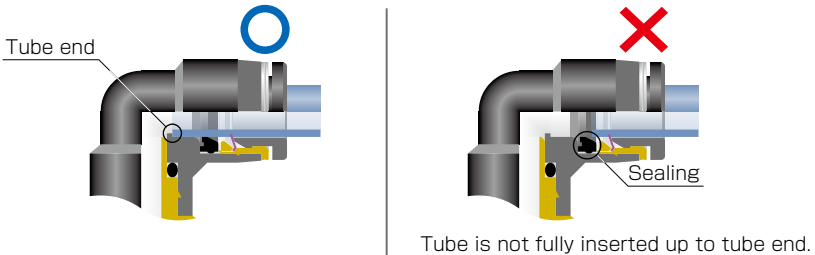

- ③. After inserting the tube, make sure it is inserted properly and not to be disconnected by pulling it moderately.
 - ※. When inserting tubes, Lock-claws may be hardly visible in the hole, observed from the front face of the release-ring. But it does not mean the tube will surely escape. Major causes of the tube escape are the followings; ① Shear drop of the lock-claws edge ② The problem of tube diameter (usually small). Therefore, follow the above instructions from ① to ③, even lock-claws is hardly visible.

7-2. Tube insertion (Compression fitting)

- ①. Make sure that the cut end surface of the tube is at a right angle without deformations or a scratch on its inner and outer surface.

- ②. Pass the tube through the nut and insert the barb into the tube up to the barb end. Then tighten the hexagonal-column of the nut with a proper tool.
- ③. Refer to Table 2 which shows the tightening torque.
 - ※. Hold the tube when tightening the nut, since the tube may rotate along with the nut.
- ④. Make sure that the nut touches the metallic body. If not, loosen the nut, disconnect the tube and start over again from the process ①.
- ⑤. Make sure that there is no leakage after tightening the nut.
- ⑥. After inserting the tube, make sure it is inserted properly and not to be disconnected by pulling it moderately.

● Table 2. Nut tightening torque

Tube O.D.	Tightening torque
ø10	Max.4N·m
ø12	Max.5N·m
ø16	Max.14N·m

8-1. Tube disconnection (Push-in fitting)

- ①. Make sure there is no air pressure inside of the tube, before disconnecting it.
- ②. Push the release-ring of the push-in fitting evenly and deeply enough to pull out the tube toward oneself. By insufficient pushing of the release-ring, the tube may not be pulled out or damaged by scratch, and tube shavings may remain inside of the fitting, which may cause the leakage later.

8-2. Tube disconnection (Compression fitting)

- ①. Make sure there is no air pressure inside of the tube, before disconnecting it.
- ②. Use a proper tool to loosen the nut. Then disconnect the tube.

9. Installation of a fitting

- ①. When installing a fitting, use proper tools to tighten a hexagonal-column or an inner hexagonal socket. When inserting a hex key into the inner hexagonal socket of the fitting, be careful so that the tool does not touch lock-claws. The deformation of lock-claws may result in a poor performance of systems or an escape of the tube.
- ②. Refer to Table 3 which shows the tightening torque. Do not exceed these limits to tighten a thread. Excessive tightening may break the thread part or deform the gasket to cause a fluid leakage. Tightening thread with tightening torque lower than these limits may cause a loosened thread or a fluid leakage. Since the sealability is affected by the processing condition of the installing part, adjust the tightening torque or correct the installing part, according to the condition.
- ③. Adjust the tube direction while tightening thread within these limits, since some PISCO products are not rotatable after the installation.

● Table 3. Tightening torque / Sealock color / Gasket materials

Thread type	Thread size	Tightening torque	Sealock color	Gasket material
Metric thread	M3 × 0.5	0.7N·m	n/a	SUS304+NBR SPCC+NBR
	M5 × 0.8	1 ~ 1.5N·m		
	M6 × 1	2 ~ 2.7N·m		
	M3 × 0.5	0.7N·m		POM
	M5 × 0.8	1 ~ 1.5N·m		
	M6 × 0.75	0.8 ~ 1N·m		
Taper pipe thread	M8 × 0.75	1 ~ 2N·m	White	—
	R1/8	4.5 ~ 6.5N·m		
	R1/4	7 ~ 9N·m		
	R3/8	12.5 ~ 14.5N·m		
Unified thread	R1/2	20 ~ 22N·m	n/a	SUS304+NBR, SPCC+NBR
	No.10-32UNF	1 ~ 1.5N·m		
National Pipe Thread Taper (American standard)	1/16-27NPT	4.5 ~ 6.5N·m	White	—
	1/8-27NPT	4.5 ~ 6.5N·m		
	1/4-18NPT	7 ~ 9N·m		
	3/8-18NPT	12.5 ~ 14.5N·m		
	1/2-14NPT	20 ~ 22N·m		
G thread	G1/4	12 ~ 14N·m	n/a	Aluminum + PBT
	G3/8	22 ~ 24N·m		
	G1/2	28 ~ 30N·m		

※. These values may differ for some products. Refer to each specification as well.

- ④. When removing a fitting, use proper tools to loosen a hexagonal-column or an inner hexagonal socket. When inserting a hex key into the inner hexagonal socket of the fitting, be careful so that the tool does not touch lock-claws. The deformation of lock-claws may result in a poor performance of systems or an escape of the tube.
 - ⑤. Remove the sealant stuck on the mating equipment. The remained sealant may get into the peripheral equipment and cause malfunctions.
- ### 10. Handling of fitting
- ①. Impact caused by dropping or the like may lead to damage to the product and a fluid leakage.