

Order example

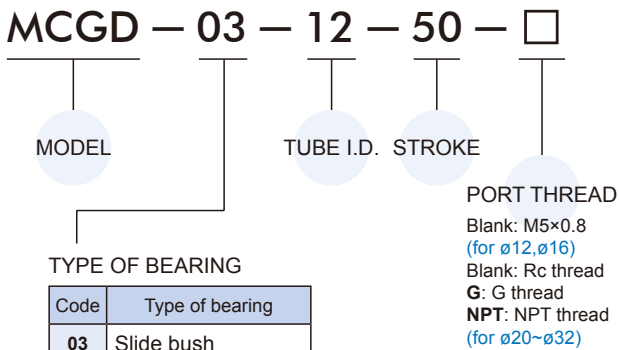

Installation of sensor switch

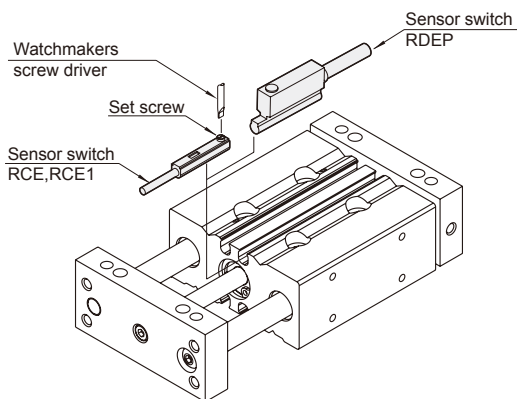

Features

- Can be used as plate slide type or body slide type.
- The air cylinder and guide share a compact design which enables the cylinder to work smoothly along its stroke.
- The cylinder is extremely rigid and strong.
- Flush fitting sensor available.
- Magnetic as standard.

Specification

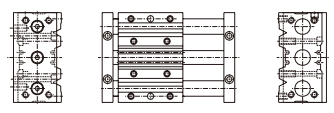
Model	MCGD	
Model (Stop type view)		
Acting type	Double acting	
Tube I.D.(mm)	12,16	20,25,32
Port size	M5×0.8	Rc1/8
Medium	Air	
Operating pressure range	0.1~1 MPa	
Proof pressure	1.5 MPa	
Ambient temperature	-5~+60°C (No freezing)	
Cushion	With rubber cushion pad	
Available speed range	50~500 mm/sec	
Lubrication	Not required	
Sensor switch (*)	RCE, RCE1, RDEP	

* RCE, RCE1, RDEP specification, please refer to page 8-10, 14.

Table for standard stroke

Series variety (Bearing type)	Tube I.D.	Stroke (mm)									
		30	50	75	100	125	150	175	200	250	300
MCGD-03 (Slide bush)	ø12										
	ø16										
	ø20										
	ø25										
	ø32										
MCGD-23 (Linear bearing)	ø12										
	ø16										
	ø20										
	ø25										
	ø32										

* Stroke out of specification is also available.

* Please consult us if stroke out of specification.

TWIN-GUIDE SLIDE CYLINDER

Deflection of guide rod by center loading (Reference)

Body Fixed

When center loading is exerted to the center of the plate.

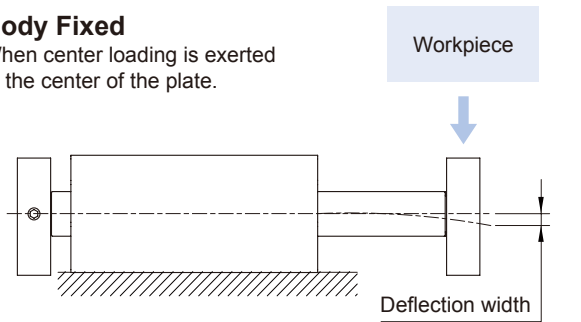

Unit: mm

Tube I.D.	Bearing type	Stroke Load (kgf)	Deflection width			
			50	100	150	200
$\phi 12$	Slide bush	0.5	0.09	0.22	—	—
	Linear bearing	0.3	0.08	0.3	—	—
$\phi 16$	Slide bush	0.5	0.03	0.1	0.25	—
	Linear bearing	0.5	0.09	0.22	0.5	—
$\phi 20$	Slide bush	0.8	0.03	0.09	0.18	—
	Linear bearing	0.5	0.03	0.1	0.25	—
$\phi 25$	Slide bush	1	0.03	0.09	0.16	—
	Linear bearing	0.8	0.03	0.09	0.18	—
$\phi 32$	Slide bush	2.9	0.02	0.05	0.1	0.15
	Linear bearing	1	0.03	0.09	0.16	0.25

Plate Fixed

When center loading is exerted to the center of the Body.

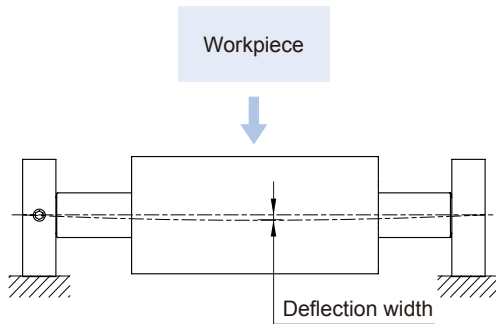

Unit: mm

Tube I.D.	Bearing type	Stroke Load (kgf)	Deflection width			
			50	100	150	200
$\phi 12$	Slide bush	3	0.06	0.08	—	—
	Linear bearing	1	0.05	0.07	—	—
$\phi 16$	Slide bush	4	0.06	0.08	0.15	—
	Linear bearing	3	0.06	0.08	—	—
$\phi 20$	Slide bush	5	0.05	0.06	0.12	—
	Linear bearing	4	0.06	0.08	0.15	—
$\phi 25$	Slide bush	6	0.04	0.05	0.07	—
	Linear bearing	5	0.05	0.06	0.12	—
$\phi 32$	Slide bush	9	0.02	0.03	0.06	0.07
	Linear bearing	6	0.04	0.05	0.07	0.08

Plate mounting methods

A Fixing the Body

The plate moves.

Mounting from the upper side

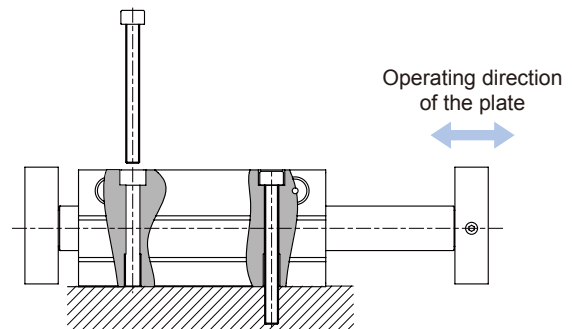

Mounting from the bottom side

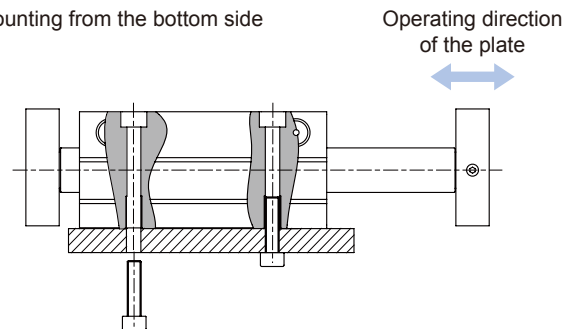

B Fixing the Plate

The body moves.

Mounting from the upper side

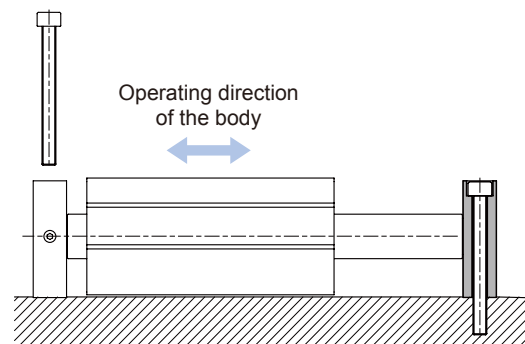

TWIN-GUIDE SLIDE CYLINDER

Maximum allowable moment

Please operate within the maximum allowable moment.

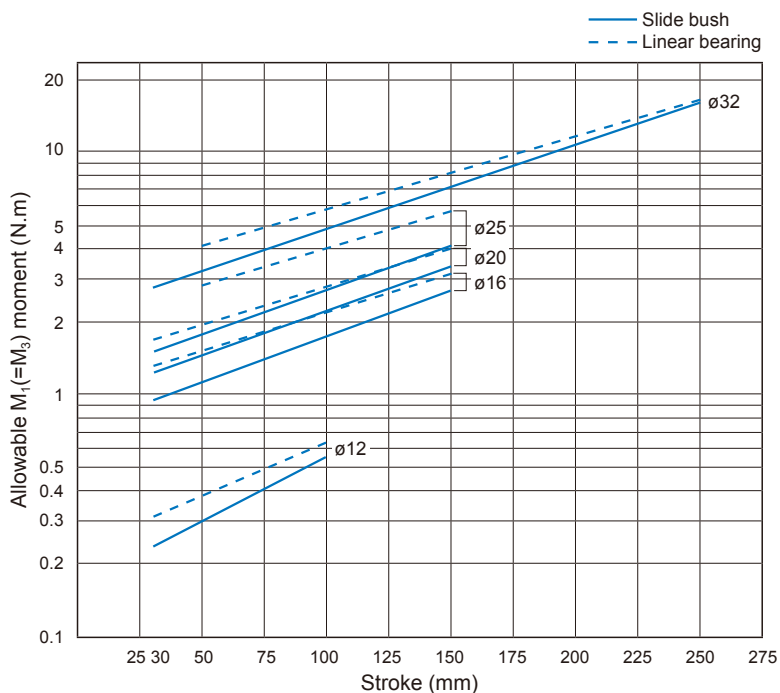
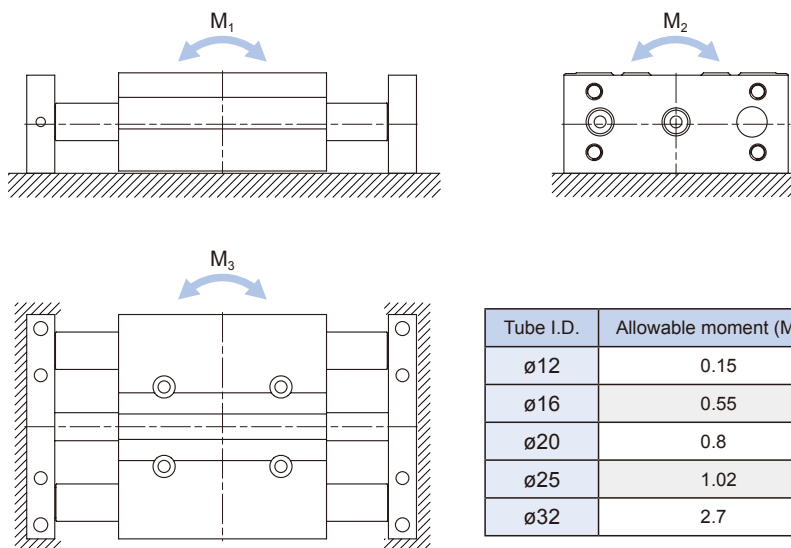

Anti-roll accuracy

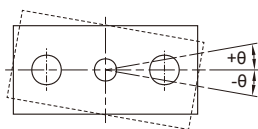

- The values are the deflection angle against the piston rod.
- Exclusive factor of the guide rods' deflection.

Tube I.D.	Bearing type	Anti-roll accuracy
		θ
$\phi 12$	Slide bush	$\pm 0.09^\circ$
	Linear bearing	$\pm 0.06^\circ$
$\phi 16$	Slide bush	$\pm 0.08^\circ$
	Linear bearing	$\pm 0.06^\circ$
$\phi 20$	Slide bush	$\pm 0.08^\circ$
	Linear bearing	$\pm 0.03^\circ$
$\phi 25$	Slide bush	$\pm 0.07^\circ$
	Linear bearing	$\pm 0.05^\circ$
$\phi 32$	Slide bush	$\pm 0.07^\circ$
	Linear bearing	$\pm 0.03^\circ$

MCGD-03

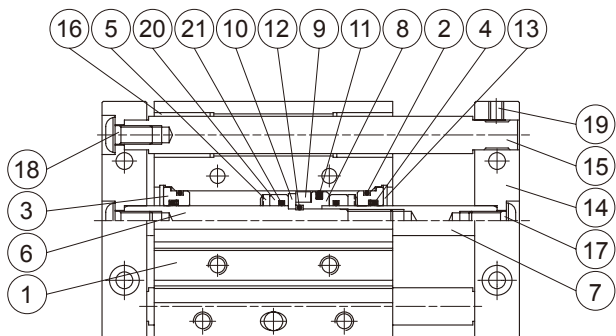

MCGD-23

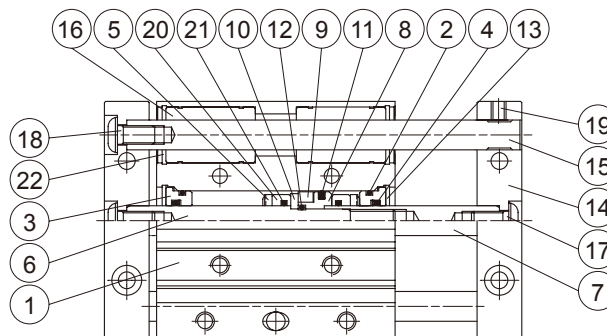

Material

No.	Part name	Material	Note	Q'y	Repair kits (inclusion)
1	Body	Aluminum alloy		1	
2	Cover ring	NBR		2	●
3	Rod cover	Aluminum alloy		2	
4	Rod packing	NBR		2	●
5	Cushion	NBR		2	●
6	Piston rod #1	Carbon steel		1	
7	Piston rod #2	Carbon steel		1	
8	Piston	Aluminum alloy		1	
9	Magnet ring	Magnet material		1	
10	Magnet ring holder	Stainless steel		1	
11	Piston packing	NBR		1	●
12	Piston gasket	NBR		1	●
13	Snap ring	Spring steel		2	
14	Plate	Aluminum alloy		2	
15	Guide rod	Carbon steel	for 03 type	2	
		Special steel	for 23 type	2	
16	Slide bush	Bearing alloy	for 03 type	4	
	Linear bearing	—	for 23 type	4	
17	Bolt for piston rod	Carbon steel		2	
18	Bolt for guide rod	Carbon steel		4	
19	Set screw	Carbon steel		2	
20	Spacer	Aluminum alloy		2	
21	O-ring	NBR		2	
22	Snap ring	Spring steel	for 23 type	4	

Order example of repair kits

Tube I.D.	Repair kits
ø12	PS-MCGD-12
ø16	PS-MCGD-16
ø20	PS-MCGD-20
ø25	PS-MCGD-25
ø32	PS-MCGD-32

MCGD-03/23

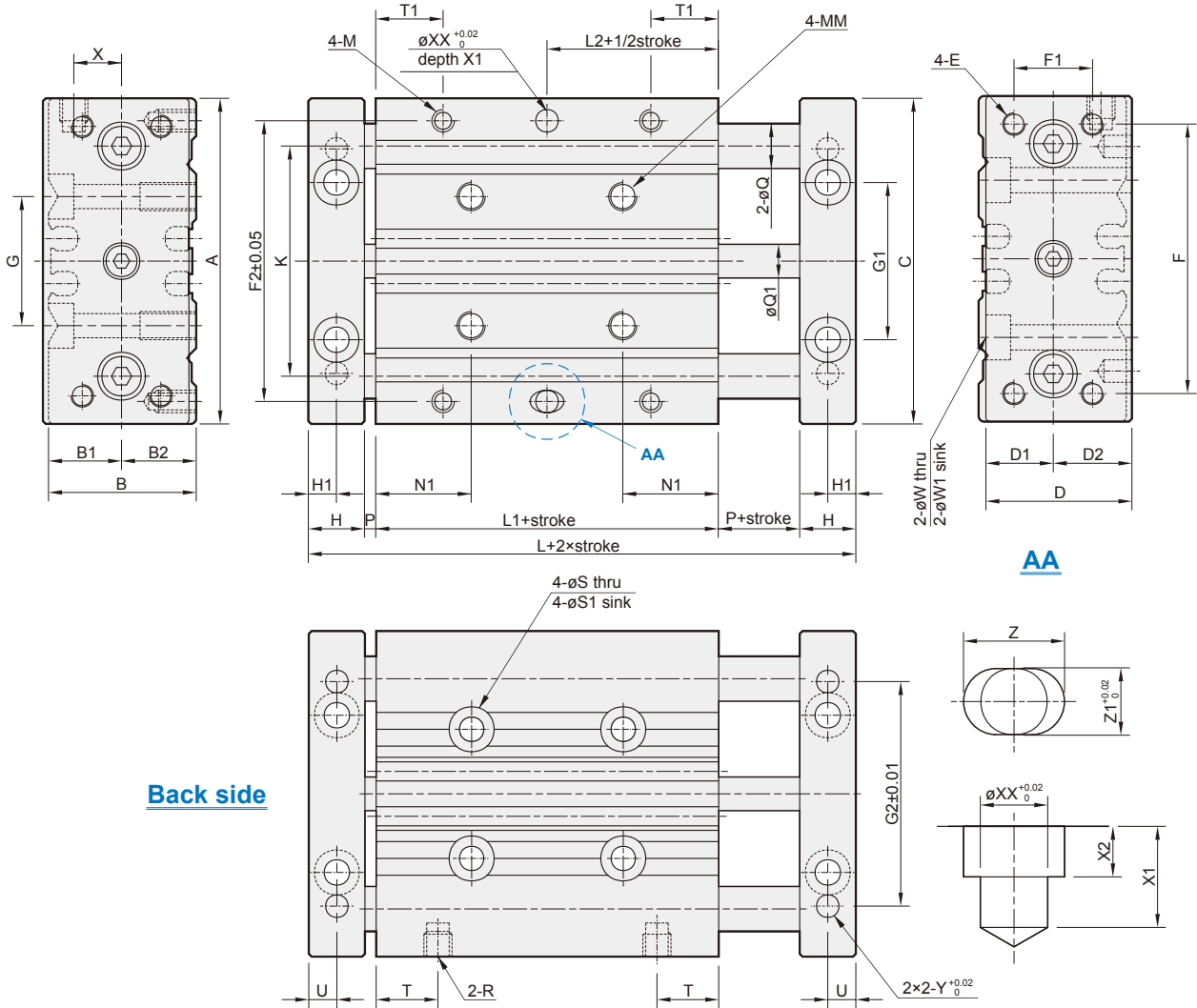

Back side

Code Tube I.D.	A	B	B1	B2	C	D	D1	D2	E	F	F1	F2	G	G1	G2	H	H1	K	L	L1	L2	M	MM	N1	Q		Q1	P	R
																								MCGD-03	MCGD-23				
12	58	26	13	13	58	26	12	14	M4	48	14	50	23	28	40	10	5	41.5	55	31	15.5	M4×7dp	M5×10dp	17	$\phi 8$	$\phi 6$	$\phi 6$	2	M5
16	64	30	15	15	64	30	14	16	M5	52	16	54	24	32	50	12	6	46	62	34	17	M5×7dp	M5×10dp	17	$\phi 10$	$\phi 8$	$\phi 8$	2	M5
20	85	36	19	17	85	36	16	20	M5	60	18	64	28	37	70	12	6	55	66	38	19	M5×7dp	M6×12dp	20.5	$\phi 12$	$\phi 10$	$\phi 10$	2	Rc1/8
25	96	42	21	21	96	42	20	22	M6	70	26	76	34	44	84	12	6	65	67	39	19.5	M6×9dp	M6×12dp	19.5	$\phi 16$	$\phi 13$	$\phi 12$	2	Rc1/8
32	116	51	25	26	116	51	24	27	M8	96	30	100	42	56	76	14	7	80	68	36	18	M8×11dp	M8×16dp	20	$\phi 20$	$\phi 16$	$\phi 16$	2	Rc1/8

Code Tube I.D.	S	S1	T	T1	U	W	W1	X	XX	X1	X2	Y	Z	Z1
12	$\phi 4.3$	$\phi 8 \times 4.5dp$	11	12	5	$\phi 4.5$	$\phi 8 \times 4.5dp$	8.5	$\phi 4$	6	3	$\phi 4 \times 5dp$	6	4
16	$\phi 4.3$	$\phi 8 \times 4.5dp$	11	13	6	$\phi 4.5$	$\phi 8 \times 4.5dp$	10	$\phi 5$	6	3	$\phi 5 \times 5dp$	7	5
20	$\phi 5.2$	$\phi 9.5 \times 5.5dp$	13.5	14	6	$\phi 5.5$	$\phi 9.5 \times 5.5dp$	11.5	$\phi 6$	8	4	$\phi 6 \times 8dp$	8	6
25	$\phi 5.2$	$\phi 9.5 \times 5.5dp$	11	12	6	$\phi 5.5$	$\phi 9.5 \times 5.5dp$	13.5	$\phi 6$	8	4	$\phi 6 \times 8dp$	8	6
32	$\phi 6.8$	$\phi 11.5 \times 6.5dp$	11	16.5	7	$\phi 6.6$	$\phi 11 \times 6.5dp$	16	$\phi 8$	12	6	$\phi 8 \times 12dp$	10	8