

1

Stepless control

Stepless control of air pressure proportional to an electrical signal.

High precision pressure control

Achieve high precision pressure control with microcomputer PID.

Certification Comply with IP65 and CE certification.

2

Compatible with modular

MAER200, 210 can be assembled with **MA**302** series.

MAER300, 310 can be assembled with **MA**401/403** series.

1

Regulator Performance

Linearity ±1% less (F.S.)

Hysteresis ±0.5% less (F.S.)

Repeatability ±0.5% less (F.S.)

Sensitivity ±0.2% less (F.S.)

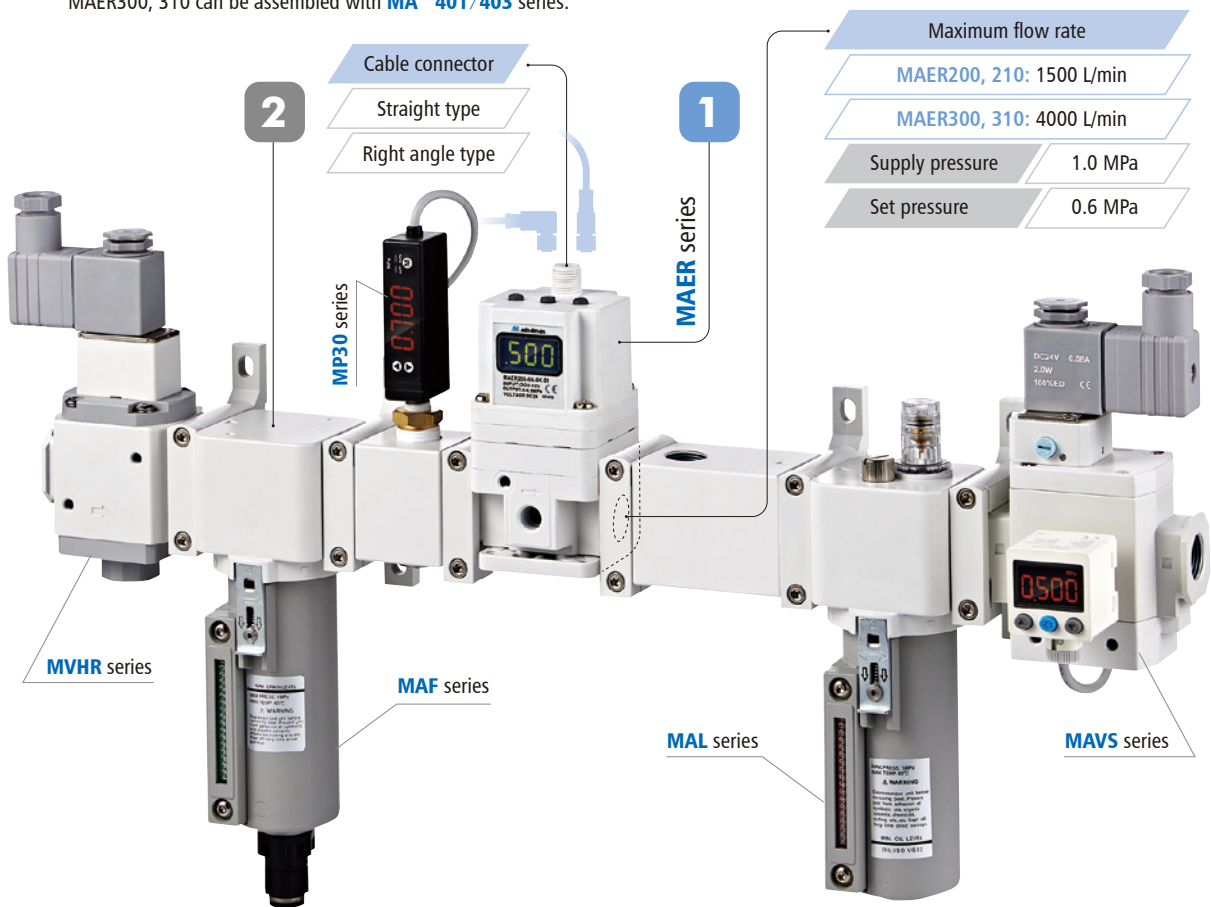

Energy saving piping

Simplify complex pipeline for controlling different pressure.
Space saving, Reduce cost, Energy saving.

VS

Tradition piping

Tradition piping for multi-stage air pressure.

MAER

=

MAR + MV*

×

n SET

Pressure setting

- 0.1 MPa
- 0.3 MPa
- 0.5 MPa
- 0.7 MPa
- ...

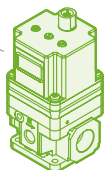

=

Regulator

Solenoid valve

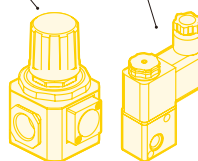

Pressure setting
0.1 MPa

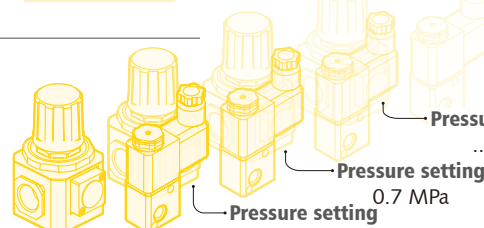

Pressure setting
0.3 MPa

Pressure setting
0.5 MPa

Pressure setting
... MPa

Pressure setting
0.7 MPa

Complex pipeline for controlling different pressure with electrical signal.

Wiring

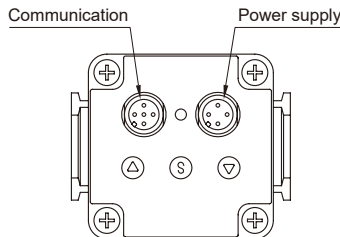

Pin assign of product connector port in RS-232 model

Port	Pin assign	Wire color ^②
Power supply ^①	1 Power supply	Brown
	2 No connect	White
	3 GND	Blue
	4 No connect	Black
Communication connect	1 No connect	Yellow
	2 T×D	Brown
	3 R×D	White
	4 GND	Green
	5 No connect	Gray

Pin assign of product connector port in RS-485 model

Port	Pin assign	Wire color ^②
Power supply ^①	1 Power supply	Brown
	2 No connect	White
	3 GND	Blue
	4 No connect	Black
Communication connect	1 No connect	Yellow
	2 B(-)	Brown
	3 A(+)	White
	4 GND	Green
	5 No connect	Gray

⚠ Warning

- ① The pin-2 and pin-4 of power supply port must be prevent to connect any signal to avoid interference or malfunction.
- ② Wire color is when the option cable is used.
- ③ Do not use power voltage exceeding specifications. The product could malfunction or catch fire if voltage exceeding the working range is applied.
- ④ Please pay attention to shielding the unused pins to avoid malfunction or abnormal function caused by noise.

Operating environment

⚠️ Caution

- 1 Avoid using this regulator where it will be subject to direct sunlight, water or oil, etc.
- 2 Use in place where the temperature changes drastically or at high humidity may cause damage due to dew condensation in the product.

Air supply

⚠️ Caution

- 1 Use clean compressed air that does not contain corrosive gas. Poor air quality adversely affects function and life.
- 2 For the pneumatic source, use cleaned air from which the solid, water and oil contents were eliminated sufficiently, using an air dryer, filter and oil mist filter. Recommend selecting a filtration precision of 5µm or less.
- 3 Do not use a lubricator on the supply side of this product, the lubricated air might cause malfunction. When lubrication of terminal equipment is necessary, connect a lubricator on the output side of the equipment and set a check valve.
- 4 When the secondary pressure is lowered with an input signal, the secondary air passes through the product and is discharged from the EXH port. Contamination on the secondary piping and the inside of the load will have an adverse effect on performance, etc. Keep the inside of the piping as clean as possible.
- 5 Tighten pipes with the appropriate torque to prevent air leakage and screw damage. First tighten the screw by hand to prevent damage to screw threads, then use a tool.
- 6 Tighten pipes with the appropriate torque. Pipes must be connected with the appropriate torque to prevent air leakages and screw damage. First tighten the screw by hand to prevent damage to screw threads, then use a tool.

Handling

⚠️ Caution

- 1 If supply pressure to this product is interrupted while the power is still on, the internal solenoid valve will continue to operate and a humming noise may be generated. Since the life of the product may be shortened, shut off the power supply also when supply pressure is shut off.
- 2 IF electric power is shut off while pressure is being applied, pressure will be retained on the output side. However, this output pressure is held only temporarily and is not guaranteed.
- 3 The product characteristics are confined to no flow in the pipeline. When air is consumed on the output side, pressure may become unstable.
- 4 Refer to the operation manual included with the product for details on its handling.
- 5 When the appliance set standby with 0 kPa input, please input an offset signal of residual pressure. If not, the inner solenoid valve will overaction to cut down the product lifespan.

- 6 Even when pressure is set to 0 MPa, secondary side pressure will not be completely released with less than 1%F.S. remaining. If precisely 0 MPa is required, bleed the secondary side or install a 3-way valve on the secondary side to switch the secondary side to atmospheric pressure.

⚠️ Warning

- 7 Do not use input signal exceeding specifications. This product could malfunction if input signal exceeding the working range is applied.
- 8 This product is adjusted for each specification at the time of shipment from the factory. Disassembling and reformation are prohibited, as this way might lead to malfunction.
- 9 If an abnormality occurs during operation, immediately turn off the power and air pressure and stop using it.

Terms

- 1 **Proof pressure:** The value of the maximum pressure that the device can endure and not to malfunction.
- 2 **Setting pressure range:** The range of the controllable pressures. Control is stopped when the input signal becomes 1% F.S. or lower.

Note. This is different from the accuracy guarantee range. See the item of linearity and hysteresis side.

- 3 **Linearity:** The error of the linear output relative to the ideal straight line, i.e. the accuracy of the analog output. It is usually expressed as a percentage compared to the entire measurement range (Full Scale: F.S.), such as 1% F.S..
- 4 **Hysteresis:** Hysteresis is the maximum difference between the rising curve and the falling curve when the input signal is varied from 0% to 100% and 100% to 0%, indicated by the percentage relative to the full scale.
- 5 **Repeatability:** Repeatability is the maximum deviation of control pressure measured when the same input signal is applied repeatedly in a short time and under the same operating conditions. Repeatability is indicated by the percentage relative to the full scale.
- 6 **Sensitivity:** Sensitivity is the minimum value of the input signal that changes the control pressure, indicated by the percentage relative to the full scale.
- 7 **Temperature characteristics:** The difference of the control pressure level made by 1°C difference of the ambient temperature (with reference temperature 25°C) is converted by calculation.

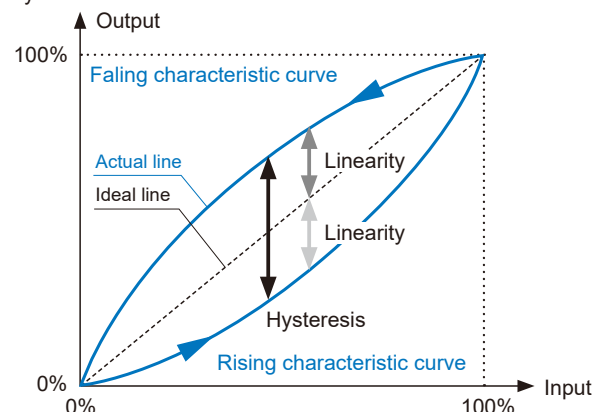



Feature

- Stepless control of air pressure proportional to an electrical signal.
- Simplify complex pipeline for controlling different pressure.
- MAER210 can be assembled with MA**302 series.
- Achieve high precision pressure control with microcomputer PID.
- Maximum flow rate 1500 L/min (Supply pressure 1.0 MPa, Set pressure 0.6 MPa).
- Comply with IP65 and CE certification.

Symbol

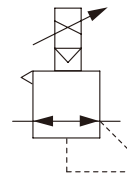

Specification

Model		MAER210		
		1K	5K	9K
Pressure range				
Bore No.		8A, 10A		
Port size		1/4, 3/8		
Medium		Air		
Proof pressure		0.3 MPa	1.5 MPa	
Ambient temperature		+5~+50°C (No condensation)		
Min. supply pressure		Set pressure +0.1 MPa		
Max. supply pressure		0.2 MPa	0.7 MPa	1 MPa
Setting pressure range (*1)		0.005~0.1 MPa	0.005~0.5 MPa	0.009~0.9 MPa
Power consumption	Voltage	DC24V±10%		
	Current	180mA or less		
Precision	Linearity	Within ±1% (F.S.)		
	Hysteresis	Within 0.5% (F.S.)		
	Repeatability	Within ±0.5% (F.S.)		
	Sensitivity	Within 0.2% (F.S.)		
Temperature characteristics		Within ±0.2% (F.S.)/°C		
Output pressure display (*2)	Precision	±2% F.S. ±1 digit		
	Min. unit	MPa:0.001, kgf/cm ² :0.01, bar:0.01, psi:0.1, kPa:1		
Enclosure		IP65		
Weight	Main	410 g		
	Accessories	Bracket: Approx. 86g(B1) , 80g(B2); Power cable connector: Approx. 130g(3m) Communication cable connector: Approx. 140g(3m)		

Communication type

Protocol	RS-232	RS-485
Address	1	1~248
Comm. speed	19.2k bps	9.6k / 19.2k / 38.4k bps
Comm. interface	Modbus ASCII	Modbus RTU

*1. Minimum setting pressure is equal to 1% F.S..

*2. Linearity setting and preset pressure setting value both are set by the minimum unit of the output pressure display.

*3. The above characteristics are confined to no flow in the pipeline. When air is consumed on the output side, pressure may become unstable.

*4. The above characteristics apply in a control pressure of 10% to 90% when power voltage is 24 VDC, ambient temperature is 25±3°C, no-loading and working pressure set at the maximum control pressure.

MAER210 Order example & Capacity



AIR UNIT (ELECTRO – PNEUMATIC REGULATOR)

mindman

Order example

MAER210 – 8A – 9K – 1 0 1 – B1 S3 CS – □

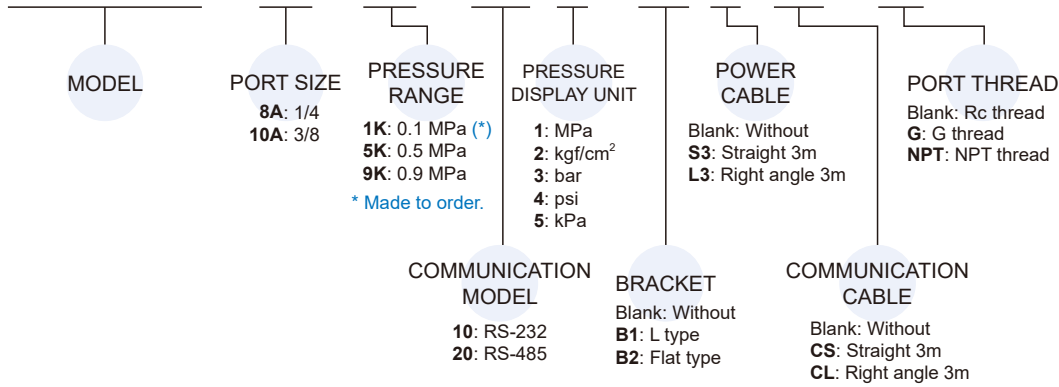

MAER210-1K

Linearity

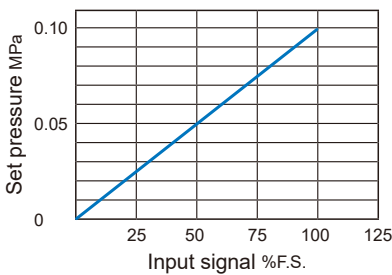

Repeatability

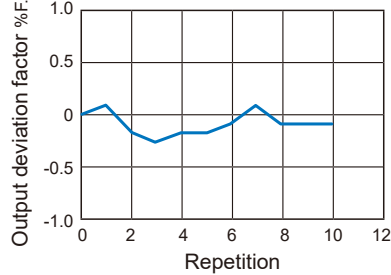

Pressure characteristics

Set pressure 0.05 MPa

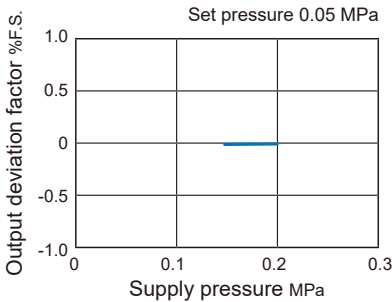

Flow rate characteristics

Supply pressure 0.2 MPa

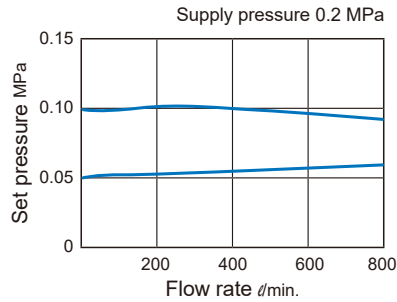

Relief flow characteristics

Back pressure 0.2 MPa

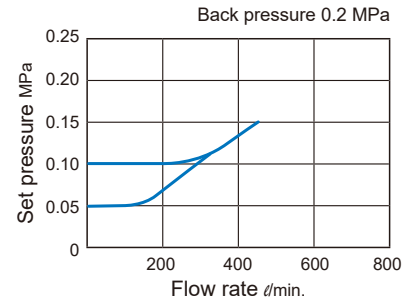

MAER210 Capacity

AIR UNIT (ELECTRO – PNEUMATIC REGULATOR)



Mindman

MAER210-5K

Linearity

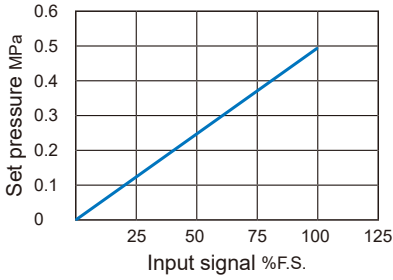

Repeatability

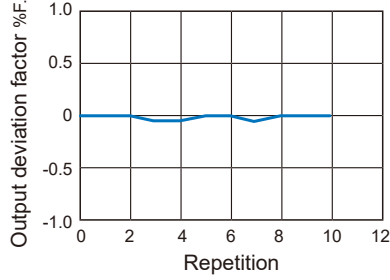

Pressure characteristics

Set pressure 0.2 MPa

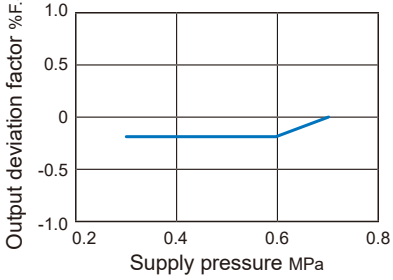

Flow rate characteristics

Supply pressure 0.7 MPa

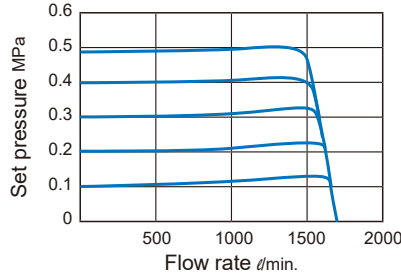

Relief flow characteristics

Back pressure 0.7 MPa

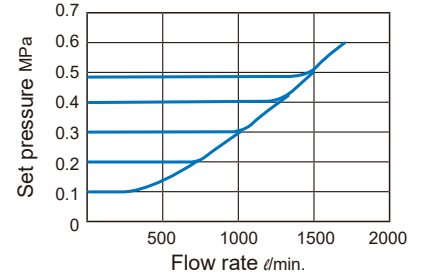

MAER210-9K

Linearity

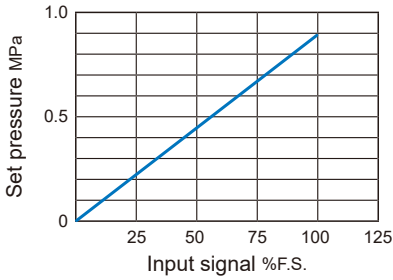

Repeatability

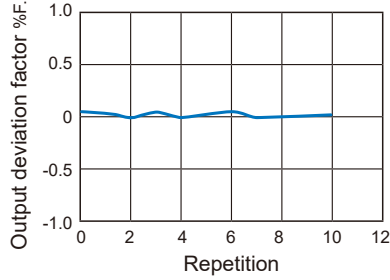

Pressure characteristics

Set pressure 0.4 MPa

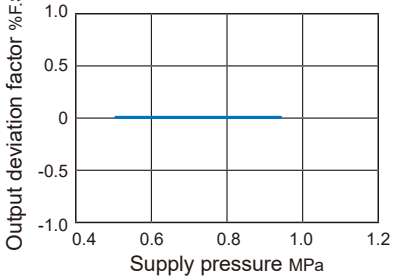

Flow rate characteristics

Supply pressure 1.0 MPa

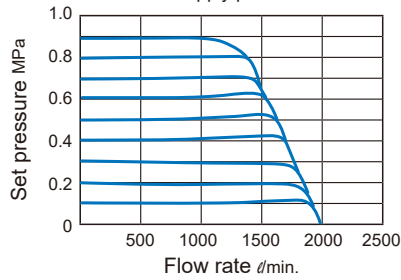

Relief flow characteristics

Back pressure 1.0 MPa

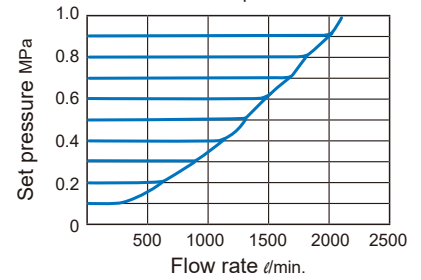

MAER210 Dimensions

AIR UNIT (ELECTRO – PNEUMATIC REGULATOR)



MAER210-B1

L type bracket

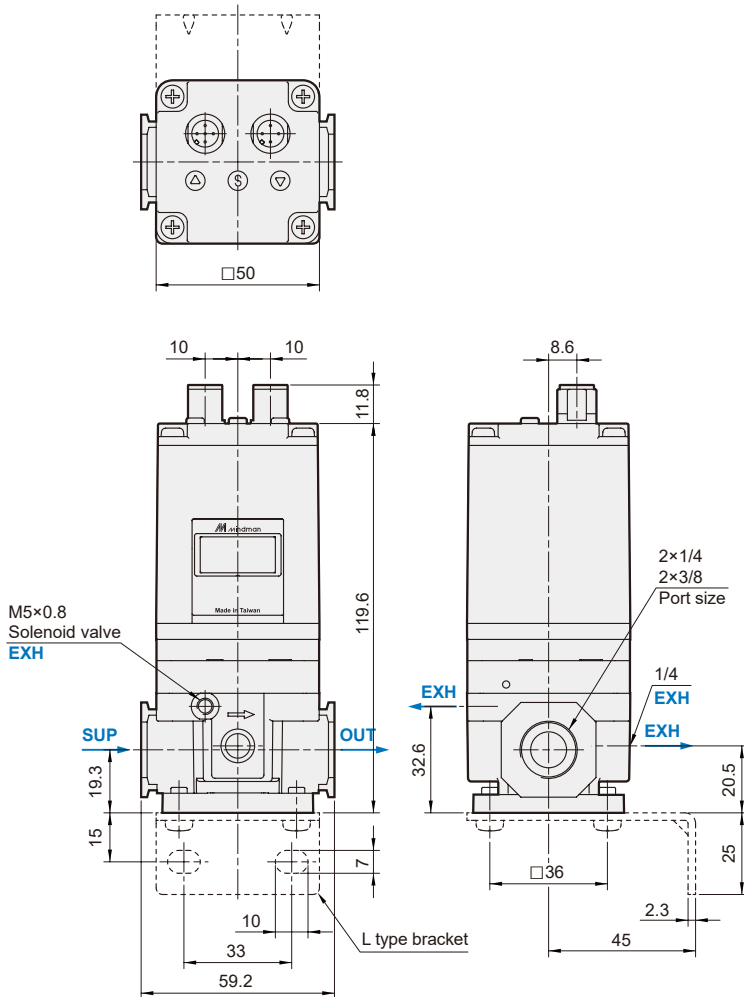

MAER210-B2

Flat type bracket

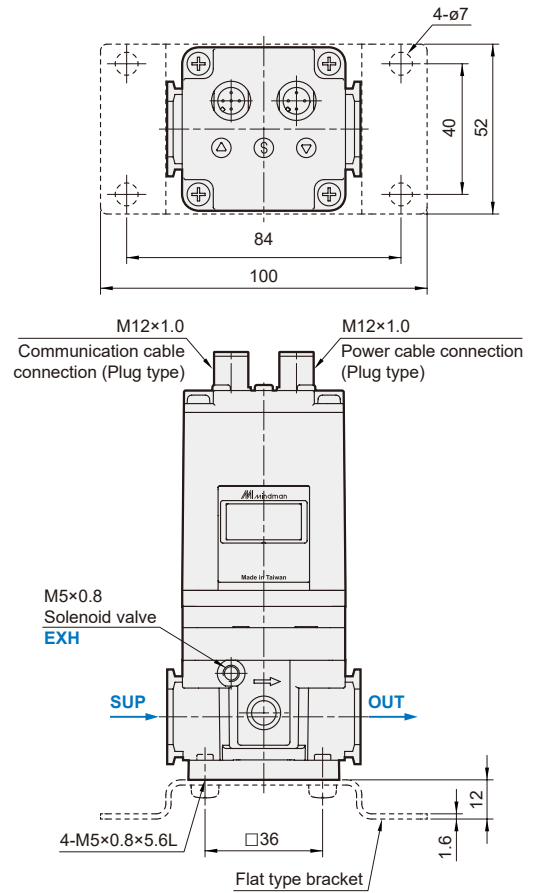

CS

Straight type communication cable

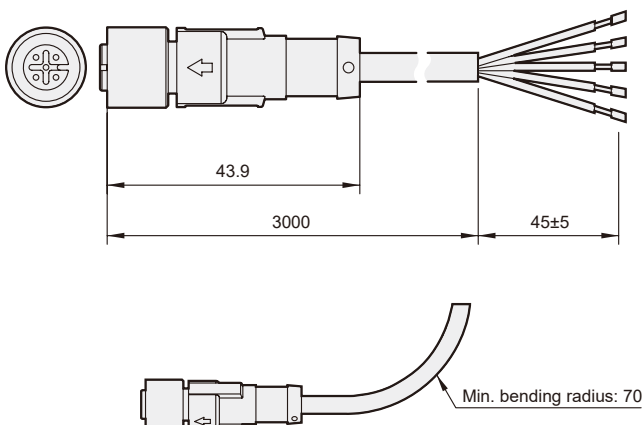

CL

Angle type communication cable

